

# Service Manual

Paper Deck

**Side Paper Deck-W1**

**Canon**



## Application

This manual has been issued by Canon Inc. for qualified persons to learn technical theory, installation, maintenance, and repair of products. This manual covers all localities where the products are sold. For this reason, there may be information in this manual that does not apply to your locality.

## Corrections

This manual may contain technical inaccuracies or typographical errors due to improvements or changes in products. When changes occur in applicable products or in the contents of this manual, Canon will release technical information as the need arises. In the event of major changes in the contents of this manual over a long or short period, Canon will issue a new edition of this manual.

The following paragraph does not apply to any countries where such provisions are inconsistent with local law.

## Trademarks

The product names and company names used in this manual are the registered trademarks of the individual companies.

## Copyright

This manual is copyrighted with all rights reserved. Under the copyright laws, this manual may not be copied, reproduced or translated into another language, in whole or in part, without the written consent of Canon Inc.

***COPYRIGHT © 2001 CANON INC.***

*Printed in Japan*

## Caution









Use of this manual should be strictly supervised to avoid disclosure of confidential information.

---

# Symbols Used



---

This documentation uses the following symbols to indicate special information:

Symbol	Description
	Indicates an item of a non-specific nature, possibly classified as Note, Caution, or Warning.
	Indicates an item requiring care to avoid electric shocks.
	Indicates an item requiring care to avoid combustion (fire).
	Indicates an item prohibiting disassembly to avoid electric shocks or problems.
	Indicates an item requiring disconnection of the power plug from the electric outlet.
 Memo	Indicates an item intended to provide notes assisting the understanding of the topic in question.
 REF.	Indicates an item of reference assisting the understanding of the topic in question.
	Provides a description of a service mode.
	Provides a description of the nature of an error indication.

The following rules apply throughout this Service Manual:

1. Each chapter contains sections explaining the purpose of specific functions and the relationship between electrical and mechanical systems with reference to the timing of operation.

In the diagrams,  represents the path of mechanical drive; where a signal name accompanies the symbol, the arrow  indicates the direction of the electric signal.

The expression "turn on the power" means flipping on the power switch, closing the front door, and closing the delivery unit door, which results in supplying the machine with power.

2. In the digital circuits, '1' is used to indicate that the voltage level of a given signal is "High", while '0' is used to indicate "Low". (The voltage value, however, differs from circuit to circuit.) In addition, the asterisk (\*) as in "DRMD\*" indicates that the DRMD signal goes on when '0'.

In practically all cases, the internal mechanisms of a microprocessor cannot be checked in the field. Therefore, the operations of the microprocessors used in the machines are not discussed: they are explained in terms of from sensors to the input of the DC controller PCB and from the output of the DC controller PCB to the loads.

The descriptions in this Service Manual are subject to change without notice for product improvement or other purposes, and major changes will be communicated in the form of Service Information bulletins.

All service persons are expected to have a good understanding of the contents of this Service Manual and all relevant Service Information bulletins and be able to identify and isolate faults in the machine."



# Contents

## Chapter 1 Specifications

1.1 Product Specifications .....	1- 1
1.1.1 Specifications .....	1- 1

## Chapter 2 Functions

2.1 Basic Operation .....	2- 1
2.1.1 Inputs to the Deck Driver PCB (1/2) .....	2- 1
2.1.2 Inputs to the Deck Driver PCB (2/2) .....	2- 2
2.1.3 Outputs from the Deck Driver PCB (1/1) .....	2- 3
2.2 Pick-Up/Feed System .....	2- 3
2.2.1 Outline .....	2- 3
2.2.2 Pickup Operation .....	2- 3
2.2.3 Sequence of Deck Pickup Sequence (A4, 2 sheets, continuous) .....	2- 5
2.3 Paper Detection .....	2- 5
2.3.1 Sequence of Deck Pickup Sequence (A4, 2 sheets, continuous) .....	2- 5
2.3.2 Switching the Paper Size .....	2- 6
2.3.3 Optical Sensors .....	2- 6
2.3.4 Deck Paper Level Detection .....	2- 6
2.4 Deck Lifter .....	2- 6
2.4.1 Detecting the Presence/Absence of Paper .....	2- 6
2.4.2 Paper Level Indicator on the Deck Front Cover .....	2- 7
2.5 Opening /Closing the Compartment .....	2- 8
2.5.1 Mechanism .....	2- 8
2.5.2 Sequence of Operations (opening/closing) .....	2- 9
2.6 Detecting Jams .....	2- 9
2.6.1 Outline .....	2- 9
2.6.2 Arrangement of Jam Sensors .....	2- 10
2.6.3 Types of Jams .....	2- 10
2.6.4 Sequence of Operations (jam detection) .....	2- 10

## Chapter 3 Parts Replacement Procedure

3.1 Removing from the Host Machine .....	3- 1
3.1.1 Compartment .....	3- 1
3.1.1.1 Removing the Compartment .....	3- 1
3.1.2 Paper Deck .....	3- 1
3.1.2.1 Detaching the Deck from the Copier .....	3- 1
3.1.2.2 Changing the Deck Paper Size .....	3- 2
3.1.2.3 Adjusting the Deck Registration .....	3- 2
3.1.2.4 Adjusting the Position of the Roll .....	3- 3
3.2 External Covers .....	3- 3
3.2.1 External Covers .....	3- 3
3.2.1.1 External Covers .....	3- 3
3.2.2 Front Cover .....	3- 3
3.2.2.1 Removing the Front Cover .....	3- 3
3.2.3 Rear Cover .....	3- 4
3.2.3.1 Removing the Rear Cover .....	3- 4
3.2.4 Right Cover .....	3- 4
3.2.4.1 Removing the Right Cover .....	3- 4
3.2.5 Upper Cover .....	3- 5

3.2.5.1	Removing the Upper Cover .....	3- 5
3.3	Drive System .....	3- 5
3.3.1	Deck Pickup Clutch .....	3- 5
3.3.1.1	Removing the Deck Pickup Clutch (CL102) .....	3- 5
3.3.2	Deck Feed Clutch .....	3- 5
3.3.2.1	Removing the Deck Feeding Clutch (CL101) .....	3- 5
3.3.3	Deck Main Motor .....	3- 6
3.3.3.1	Removing the Deck Main Motor (M101) .....	3- 6
3.3.4	Deck Lifter Motor .....	3- 6
3.3.4.1	Removing the Deck Lifter Motor (M102) .....	3- 6
3.3.5	Lifter Cable (Front) .....	3- 6
3.3.5.1	Removing the Lifter Cable (front of the deck) .....	3- 6
3.3.6	Lifter Cable .....	3- 7
3.3.6.1	Removing the Lifter Cable (rear of the deck) .....	3- 7
3.3.6.2	Routing the Lifter Cable .....	3- 8
3.4	Document Feeding System .....	3- 8
3.4.1	Deck Pickup Unit .....	3- 8
3.4.1.1	Removing the Deck Pickup Unit .....	3- 8
3.4.2	Deck Pickup Roller .....	3- 9
3.4.2.1	Removing the Deck Pickup Roller .....	3- 9
3.4.2.2	Orientation of the Deck Pickup Roller .....	3- 9
3.4.3	Deck Pickup/Feed Roller .....	3- 9
3.4.3.1	Removing the Deck Pickup/Feeding Roller .....	3- 9
3.4.3.2	Orientation of the Deck Pickup/Feeding Roller .....	3- 9
3.4.4	Deck Separation Roller .....	3- 10
3.4.4.1	Removing the Deck Separation Roller .....	3- 10
3.4.4.2	Adjusting the Pressure of the Deck Separation Roller .....	3- 10
3.4.5	Deck Pick-up Sensor .....	3- 10
3.4.5.1	Removing the Deck Pickup Sensor Unit .....	3- 10
3.4.6	Deck Feed Sensor .....	3- 10
3.4.6.1	Removing the Deck Feed Sensor Unit .....	3- 10
3.5	Electrical System .....	3- 11
3.5.1	Deck Driver PCB .....	3- 11
3.5.1.1	Removing the Side Deck Driver PCB .....	3- 11
3.5.2	Open Switch PCB .....	3- 11
3.5.2.1	Removing the Open Switch PCB .....	3- 11

## Chapter 4 Maintenance

4.1	Maintenance and Inspection .....	4- 1
4.1.1	Periodically Replaced Parts .....	4- 1
4.1.1.1	Periodically Replaced Parts .....	4- 1
4.1.2	Durables .....	4- 1
4.1.2.1	Guide to Replacement of Durables .....	4- 1
4.2	Adjustment .....	4- 2
4.2.1	Basic Adjustment .....	4- 2
4.2.1.1	Adjusting the Image Front Margin .....	4- 2
4.2.1.2	Orientation of the Pickup Roller .....	4- 2
4.2.1.3	Orientation of the Feeding Roller .....	4- 2
4.2.1.4	Positioning the Deck Pickup Roller Releasing Solenoid (SL101) .....	4- 2
4.3	Troubleshooting .....	4- 3
4.3.1	Malfunction .....	4- 3
4.3.1.1	Malfunction/Faulty Detection .....	4- 3
4.4	Outline of Electrical Components .....	4- 4
4.4.1	Arrangement of Electric Parts .....	4- 4

## Chapter 5 Error Code



5.1 Overview.....	5- 1
5.1.1 Outline .....	5- 1
5.1.2 Error Code.....	5- 1



---

## Chapter 1 Specifications

---



# Contents

1.1 Product Specifications.....	1-1
1.1.1 Specifications.....	1-1



## 1.1 Product Specifications

### 1.1.1 Specifications

T-1-1

Item	Description
Pickup	Separation roller
Paper accommodation	Side tray
Copy paper type	<ul style="list-style-type: none"> <li>- Plain paper (64 to 80 g/m<sup>2</sup>): A4, B5, LTR</li> <li>- Recycled paper (64 to 80g/m<sup>2</sup>): A4, B5, LTR</li> <li>- Eco paper: (80g/m<sup>2</sup>): A4</li> <li>- Tracing paper: A4,B5</li> <li>- Colored paper (recommended type)A4</li> <li>- Thick paper (90 to 200 g/m<sup>2</sup>): A4, B5, LTR</li> <li>- 3-hole paper (horizontal feed, restrictions on orientation): LTR</li> </ul>
Stack height	385 mm (approx.; about 3,500 sheets of 80 g/m <sup>2</sup> paper, about 4,000 sheets of 64 g/m <sup>2</sup> paper)
Paper size switch	by switching size guide plate (multiple settings) and size in service mode (OPTION)
Dimensions	326.2 (W) X 583 (D) X 574.5 (H) mm (approx.)
Weight	46 kg (approx.)
Power supply	DC from host machine
Operating environment	Same as copier

The above specifications are subject to change for product improvement.





---

## Chapter 2 Functions

---



---

# Contents

2.1 Basic Operation.....	2-1
2.1.1 Inputs to the Deck Driver PCB (1/2) .....	2-1
2.1.2 Inputs to the Deck Driver PCB (2/2) .....	2-2
2.1.3 Outputs from the Deck Driver PCB (1/1) .....	2-3
2.2 Pick-Up/Feed System .....	2-3
2.2.1 Outline.....	2-3
2.2.2 Pickup Operation .....	2-3
2.2.3 Sequence of Deck Pickup Sequence (A4, 2 sheets, continuous) .....	2-5
2.3 Paper Detection .....	2-5
2.3.1 Sequence of Deck Pickup Sequence (A4, 2 sheets, continuous) .....	2-5
2.3.2 Switching the Paper Size .....	2-6
2.3.3 Optical Sensors .....	2-6
2.3.4 Deck Paper Level Detection .....	2-6
2.4 Deck Lifter .....	2-6
2.4.1 Detecting the Presence/Absence of Paper.....	2-6
2.4.2 Paper Level Indicator on the Deck Front Cover .....	2-7
2.5 Opening /Closing the Compartment .....	2-8
2.5.1 Mechanism .....	2-8
2.5.2 Sequence of Operations (opening/closing) .....	2-9
2.6 Detecting Jams .....	2-9
2.6.1 Outline.....	2-9
2.6.2 Arrangement of Jam Sensors .....	2-10
2.6.3 Types of Jams .....	2-10
2.6.4 Sequence of Operations (jam detection) .....	2-10



## 2.1 Basic Operation

### 2.1.1 Inputs to the Deck Driver PCB (1/2)

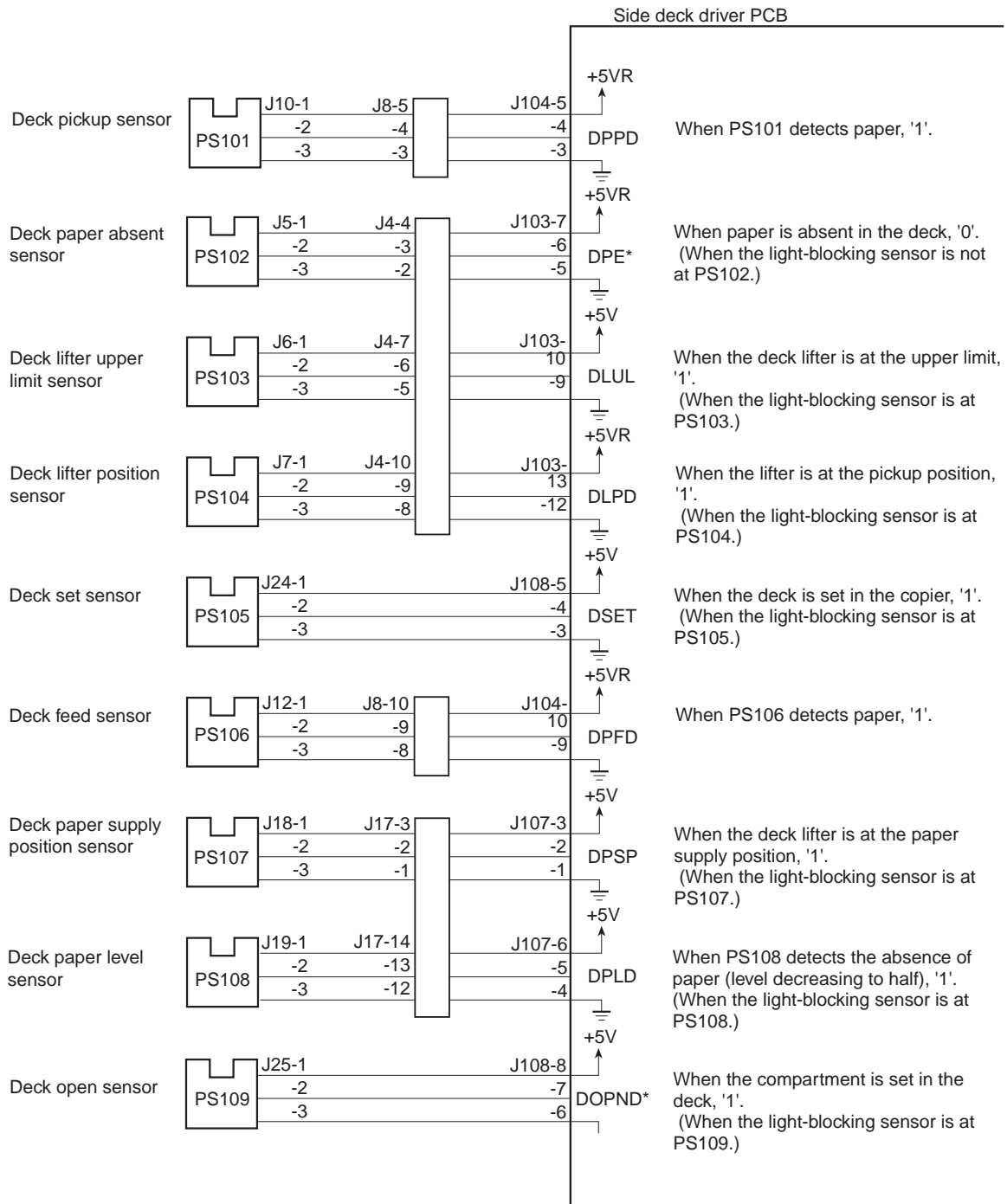

F-2-1

2.1.2 Inputs to the Deck Driver PCB (2/2)

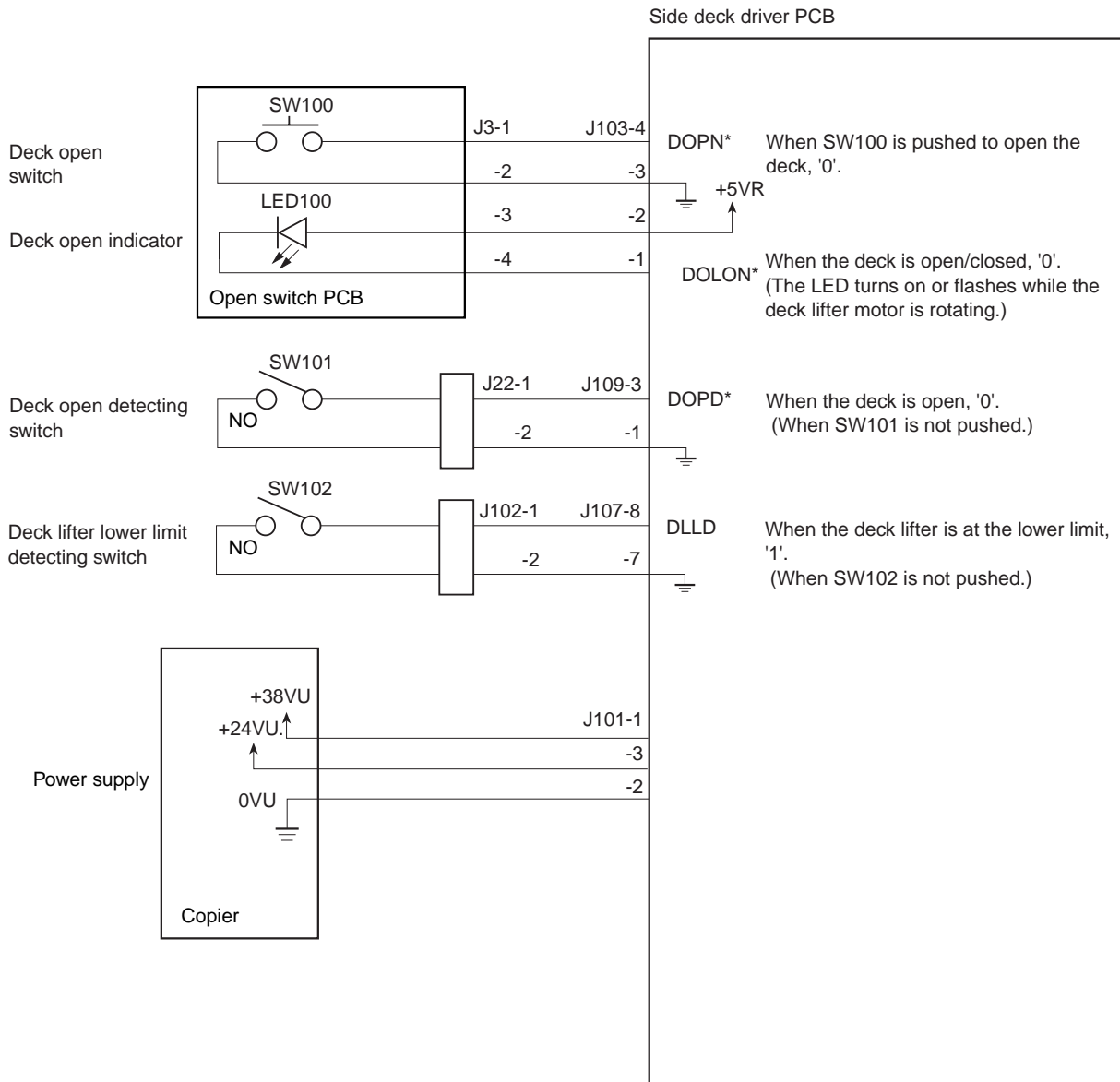

F-2-2

2.1.3 Outputs from the Deck Driver PCB (1/1)

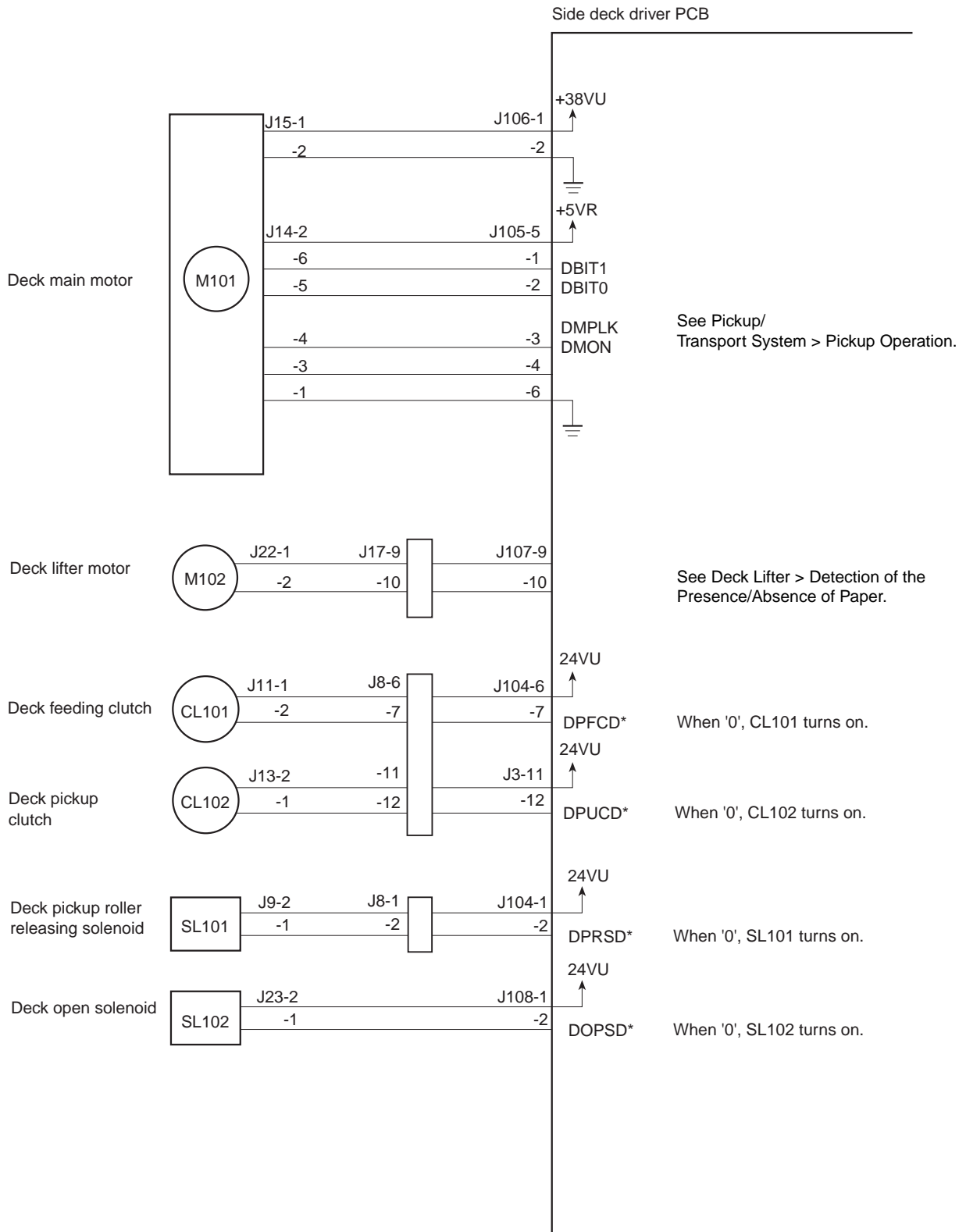

F-2-3

2.2 Pick-Up/Feed System

2.2.1 Outline

The side paper deck (hereafter, "deck") is capable of holding as many as 3,500 sheets of paper (A4/LTR/B5 of 80 g/m2), and operates in response to the control signals from the copier's DC controller. The lifter of the deck is driven by the deck lifter motor (M102), and paper is picked up and moved by the drive of the deck main motor (M101).

2.2.2 Pickup Operation

The paper set in the deck is held up by the lifter, and is kept at a specific position. When the Copy Start key is pressed and the deck pickup clutch (CL102) turns on, the drive of the deck main motor (M101) rotates the pickup roller to start pickup

operation. At this time, the pickup/feeding roller and the separation roller serve to make sure that only one sheet of paper is picked up. Then, when the deck pickup sensor (PS101) detects paper, the deck pickup roller releasing solenoid (SL101) turns on so that the pickup roller leaves the surface of paper. The deck feeding roller starts to rotate when the deck feeding clutch (CL101) turns on. Then, the paper that has been picked up is moved to the copier's registration roller, and is made to arch so as to remove the skew. The registration roller controls the paper so that its leading edge and the leading edge of the image on the photosensitive drum match.

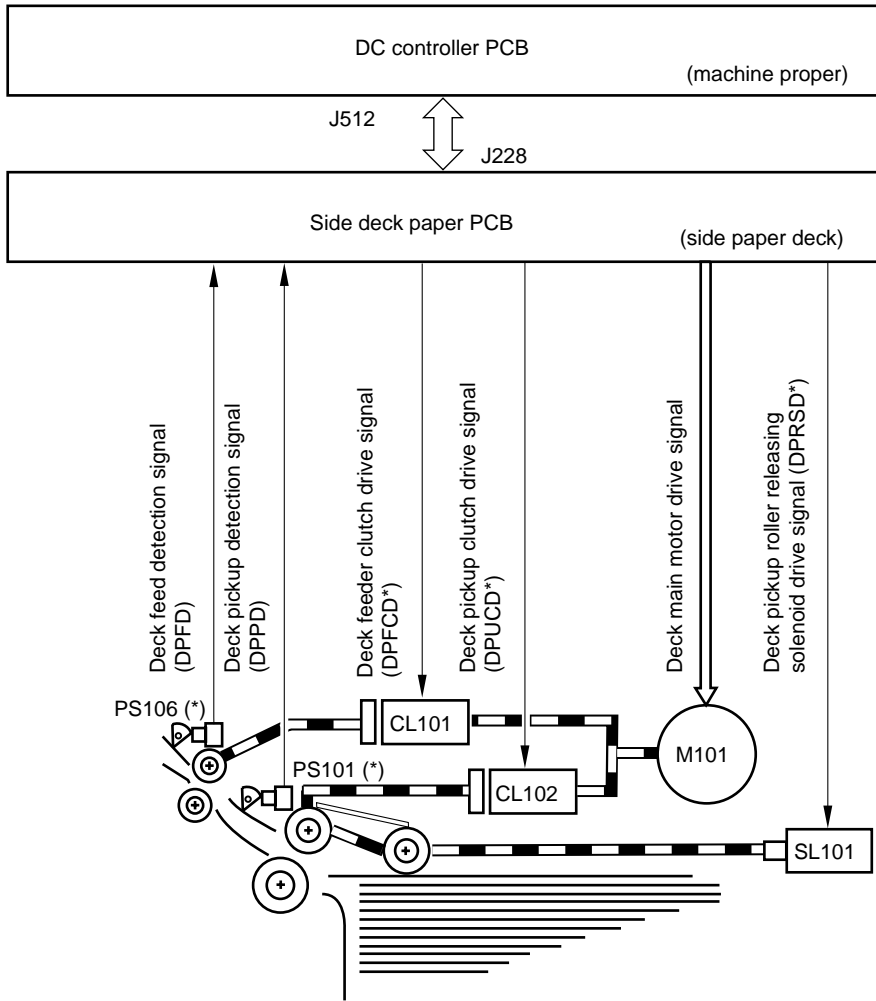

F-2-4

\*PS101,PS106: Optical sensor



2.2.3 Sequence of Deck Pickup Sequence (A4, 2 sheets, continuous)

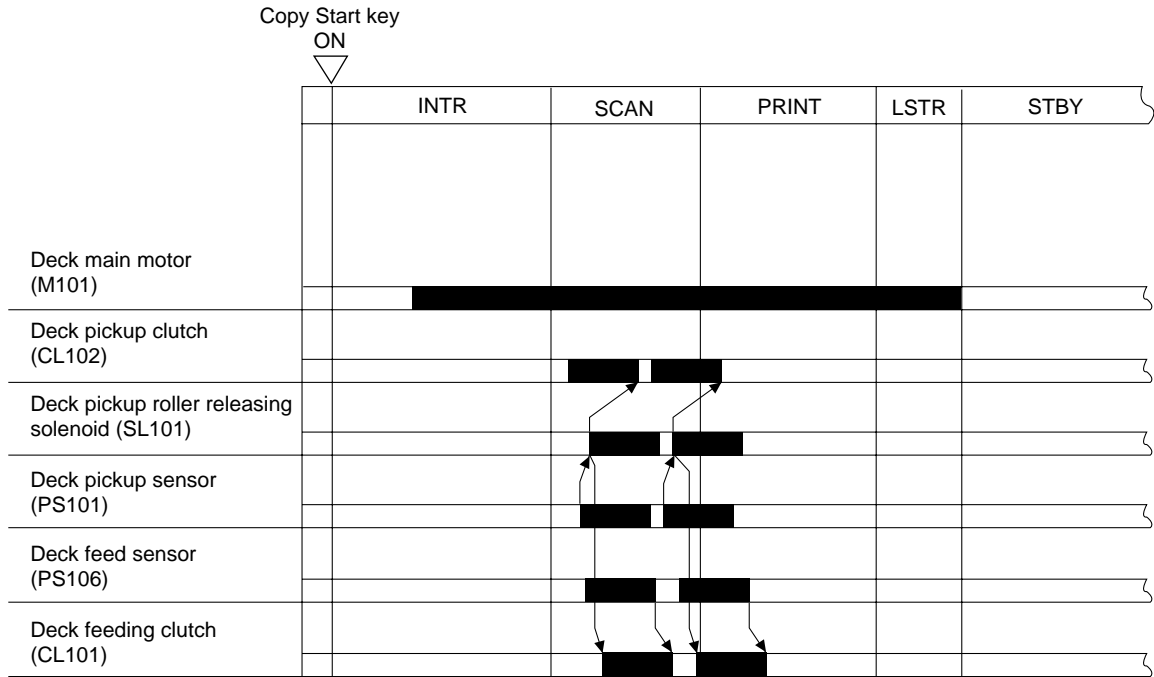

F-2-5

2.3 Paper Detection

2.3.1 Sequence of Deck Pickup Sequence (A4, 2 sheets, continuous)

The presence/absence of paper inside the deck is detected by the deck paper absent sensor (PS102). When the deck runs out of paper and, as a result, the paper detecting lever of the pickup roller assembly leaves the deck paper absent sensor, the copier's control panel will indicate the absence of paper.

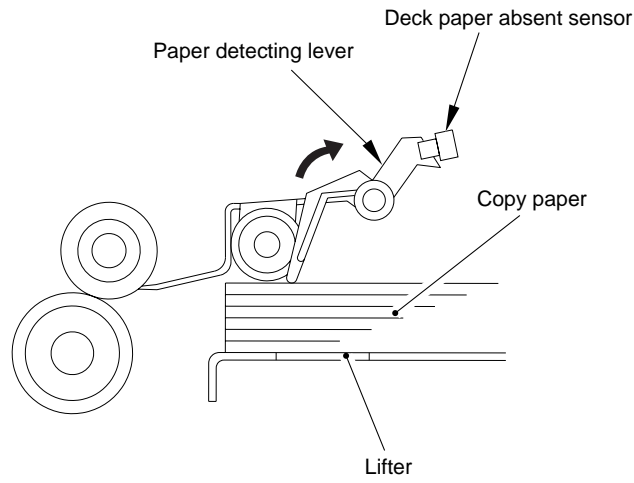

F-2-6

Paper Absent

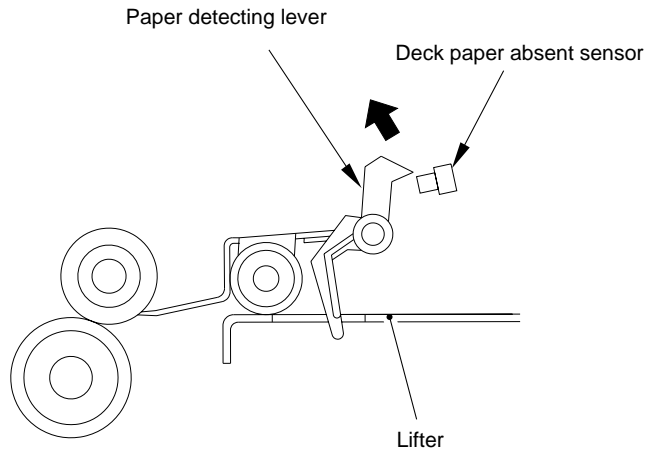

F-2-7

### 2.3.2 Switching the Paper Size

To change the deck paper size, move the guide plate inside the deck at time of installation or in response to the user's request, and enter the new paper size in service mode (OPTION > ACC > DK-P).

### 2.3.3 Optical Sensors

To accommodate the increase in the process speed, the machine uses a combination of an optical sensor [1] and a prism [2] instead of a photo sensor and a sensor flag for some of the sensors in the pickup/feeding assembly, thus ensuring correct detection of paper.

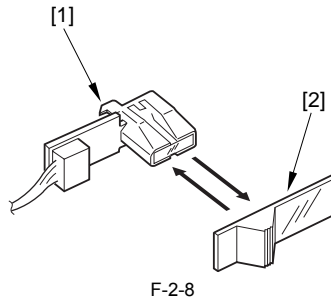

### 2.3.4 Deck Paper Level Detection

The deck uses the deck paper supply position sensor (PS107), deck paper level sensor (PS108), and deck paper absent sensor (PS102) to find out and communicate to the copier an approximate level of paper inside its compartment so that the level may be indicated in the copier's control panel. Table 10-101 shows the possible combinations of sensor outputs and levels of paper.

T-2-1

Paper level	PS102	PS107	PS108	Control panel indication
About 1750 to 3500 sheets	1	1	1	☰
About 500 to 1750 sheets	1	1	0	☱
1 to about 500 sheets	1	0	0	☲
0	0	0	0	☳

- 1: The light-blocking plate is over the sensor.
- 0: The light-blocking plate is not over the sensor.

## 2.4 Deck Lifter

### 2.4.1 Detecting the Presence/Absence of Paper

The lifter of the deck is connected to a reel by means of a cable, and is driven by the deck lifter motor (M102). The lifter is moved up or down by changing the direction of rotation of the motor.

When the deck (compartment) is pushed inside the copier, the deck open detecting switch (SW101) is pushed; the lifter stops when the deck open sensor (PS109) detects the light-blocking plate.

The deck lifter upper limit sensor (PS103) is used to prevent damage to the deck in the event that the lifter fails to stop moving up beyond the deck lifter position sensor because of some fault.

The lifter starts to move down as soon as the deck open switch (SW100) is pushed, and continues to move down until the deck paper supply position sensor (PS107) leaves the sensor lever (falling edge of the sensor output).

When paper is supplied, the paper will push the lever of the deck paper supply position sensor, causing the lifter to move farther down until the stack of paper leaves the sensor lever.

The lifter repeats downward movement each time paper is supplied until it pushes the deck lifter lower limit detecting switch (SW102; maximum paper supply position).

The copier's DC-CPU monitors the combination of sensor outputs (activation) related to the movement of the deck lifter; when the deck lifter position sensor (PS104) output and the deck level sensor position sensor (PS108) output are '1' and the deck paper supply position sensor (PS107) is '0' (not likely in practice), the copier's control panel will indicate 'E041'.

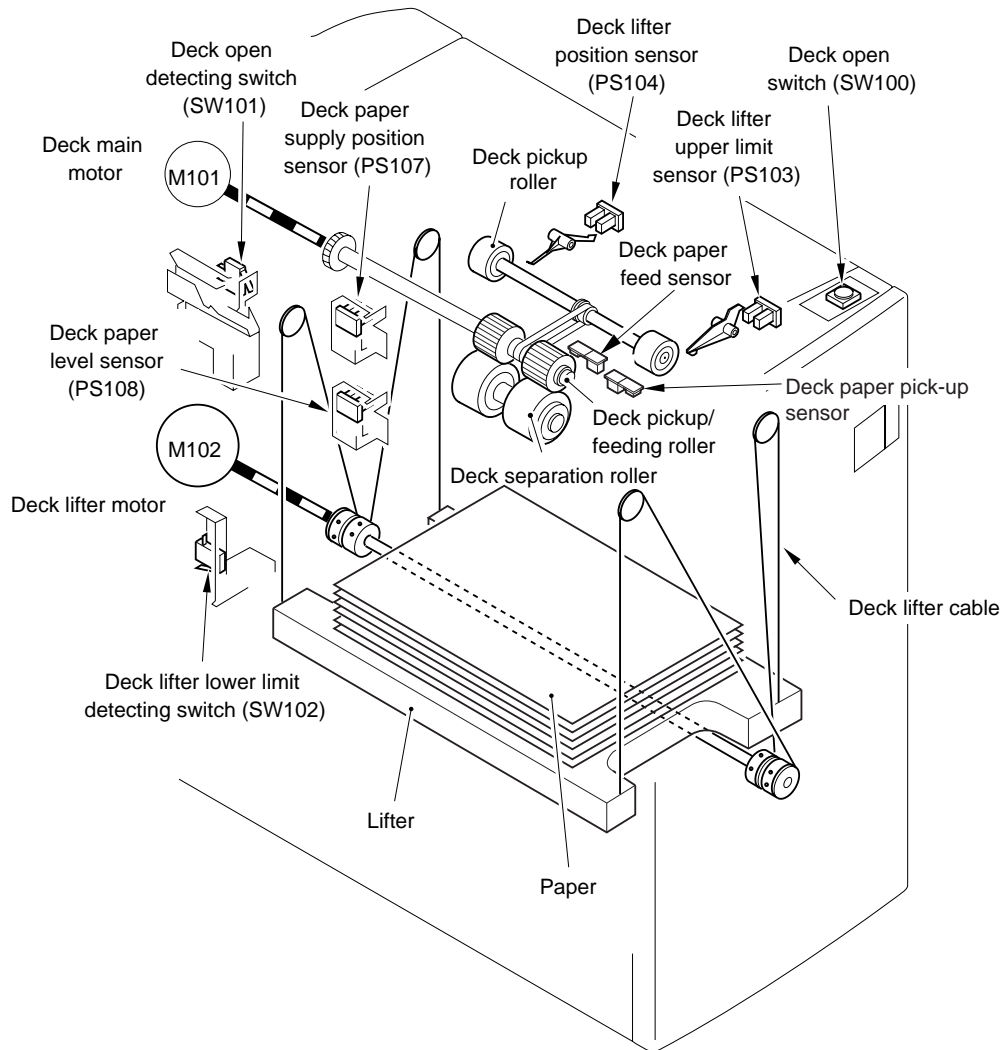

F-2-9

#### 2.4.2 Paper Level Indicator on the Deck Front Cover

The drive of the deck lifter motor (M102) is received by a coupling, and is forwarded to the rack by a drive belt. The rack is equipped with a black belt, which moves up and down within the indicator window placed in the deck front cover. When the level of paper lowers and, as a result, the lifter moves up to pickup position, the area of the black belt within the indicator window increases gradually, decreasing the white area so as to indicate the decreasing level of paper.

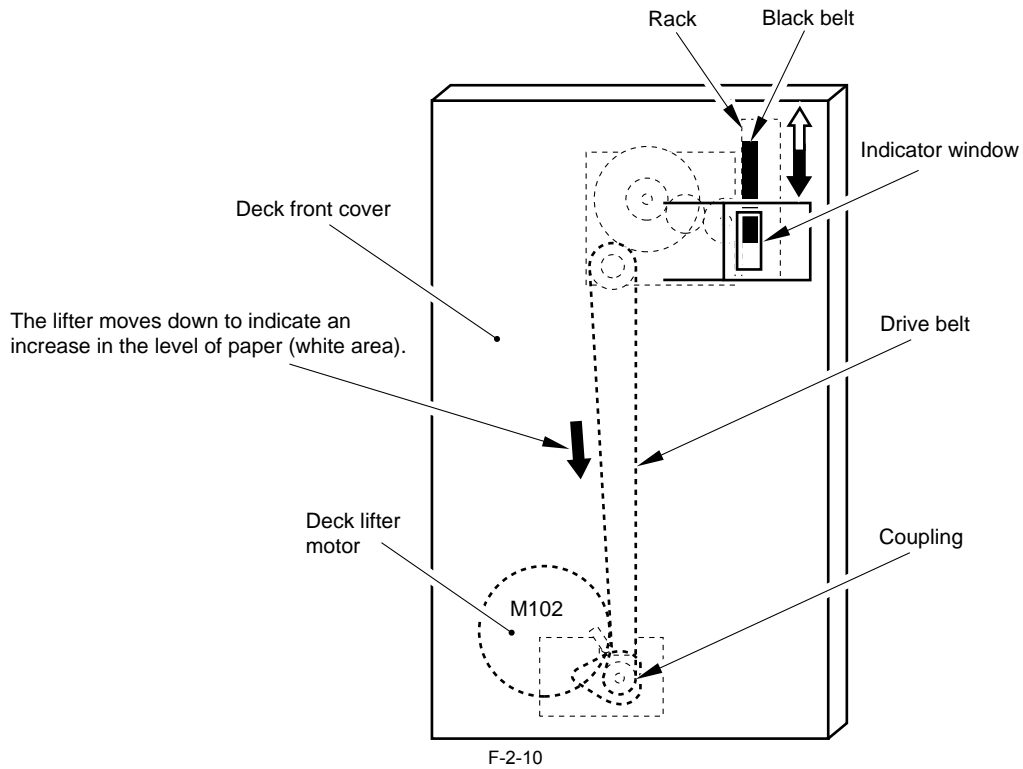

## 2.5 Opening /Closing the Compartment

### 2.5.1 Mechanism

When the deck open switch (SW100) is pushed, the deck open solenoid (SL102) turns on to release the deck (compartment), causing the deck to be pushed several centimeters to the front by the work of a spring. At the same time, the deck lift motor (M102) starts to rotate, and the lifter inside the deck moves down. When the deck (compartment) is pushed inside the copier manually, the deck open sensor (PS109) detects the light-blocking plate of the compartment, and the lifter moves up to the pickup position.

When the deck lifter motor starts to rotate as when the deck is opened or closed, the deck open indicator (LED100) on the open switch PCB will turn on or flash.

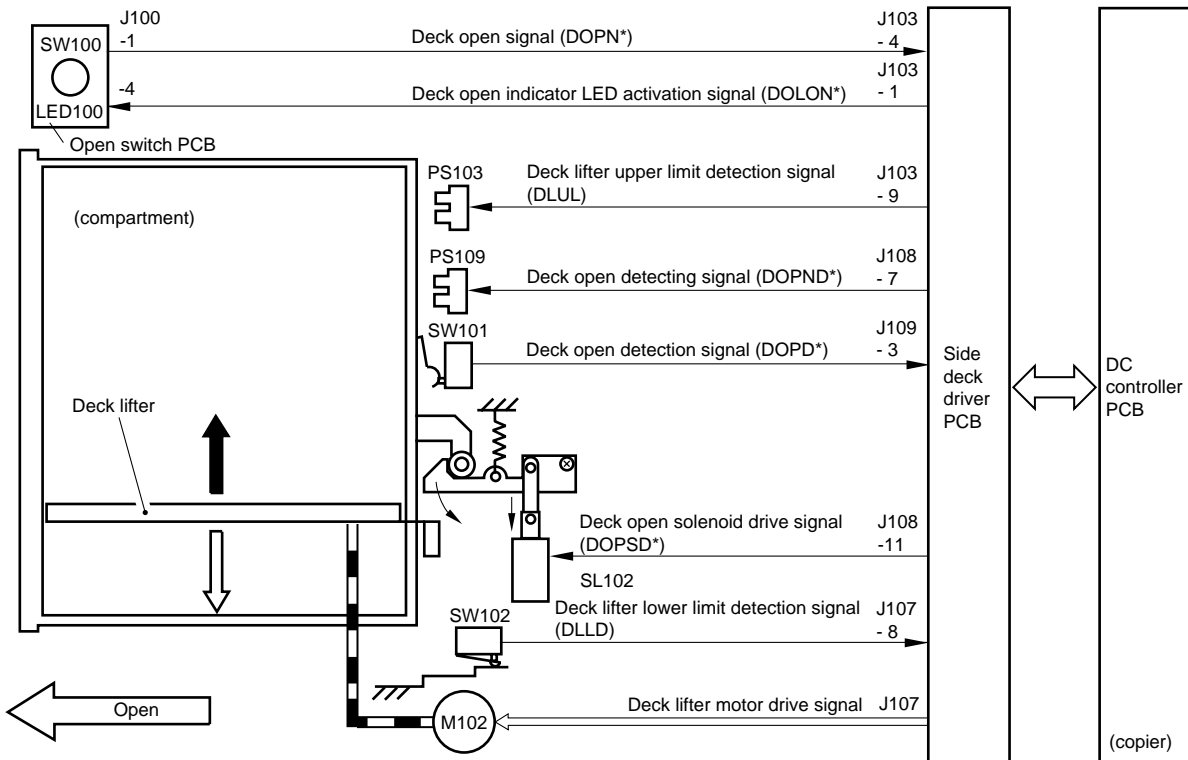

2.5.2 Sequence of Operations (opening/closing)

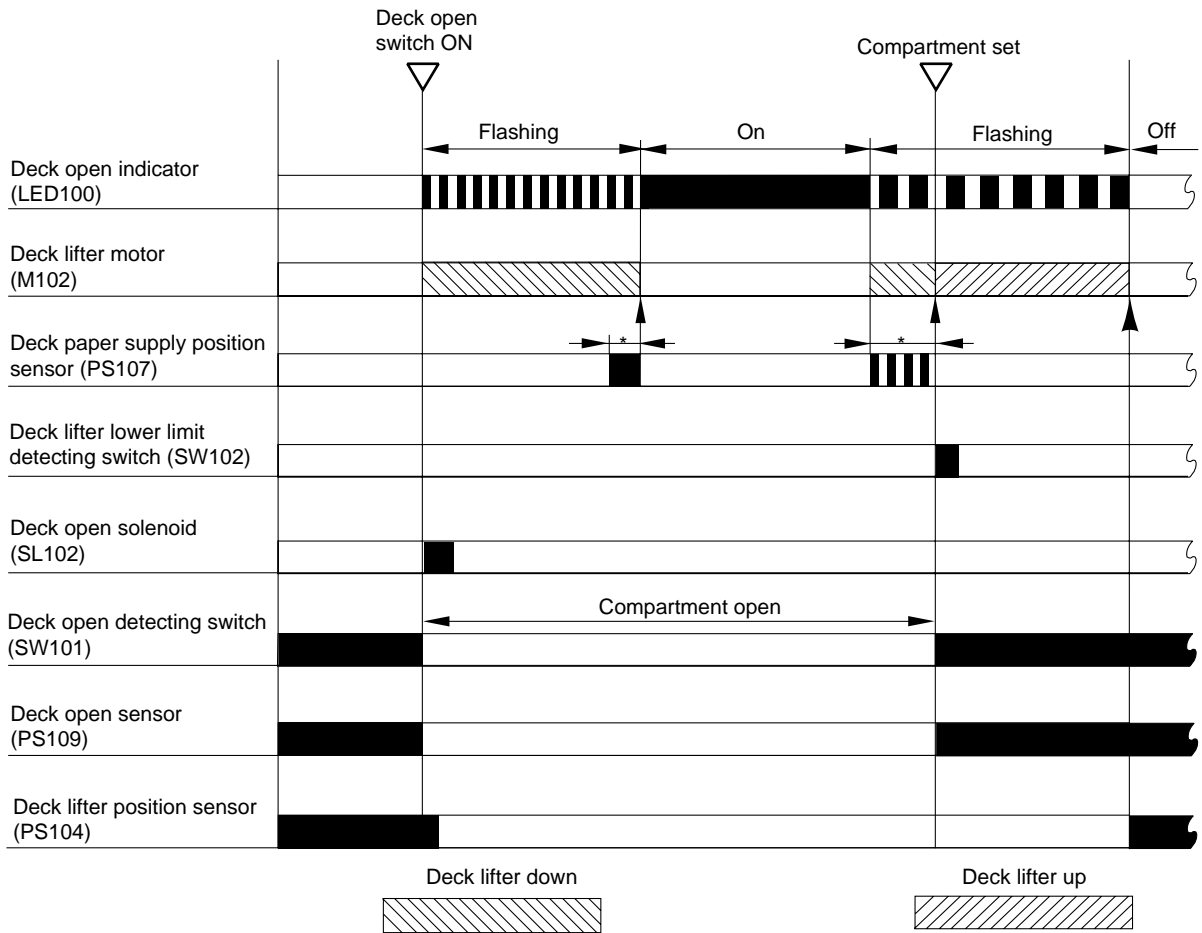

\* : Varies according to the level of the stack.

F-2-12

2.6 Detecting Jams

2.6.1 Outline

The side paper deck is equipped with the two sensors shown in Figure 10-201 to find out whether paper is being moved normally. A jam is identified based on the outputs of the signals at such times as instructed by the copier's DC controller. When the copier's DC controller identifies a jam, all paper moving ahead of the jam is discharged and the operation is stopped. (Then, the copier's control panel shows how to remove jams.)

2.6.2 Arrangement of Jam Sensors

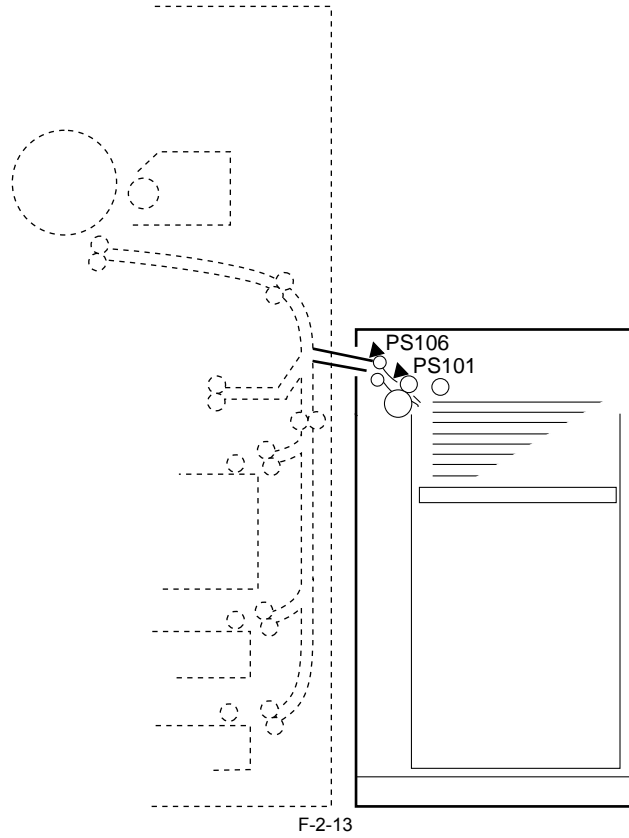

F-2-13

2.6.3 Types of Jams

T-2-2

Sensor No.	Name	Description
PS106	Deck feed sensor	Finding a delay jam
PS101	Deck pickup sensor	Finding a delay jam

2.6.4 Sequence of Operations (jam detection)

The copier's DC controller identifies a jam under the following conditions:

- When the copier's power switch is turned on, at the end of the WAIT period, or in standby, paper exists over the deck feed sensor (PS106).
- Deck Pickup/Vertical Path Delay Jam

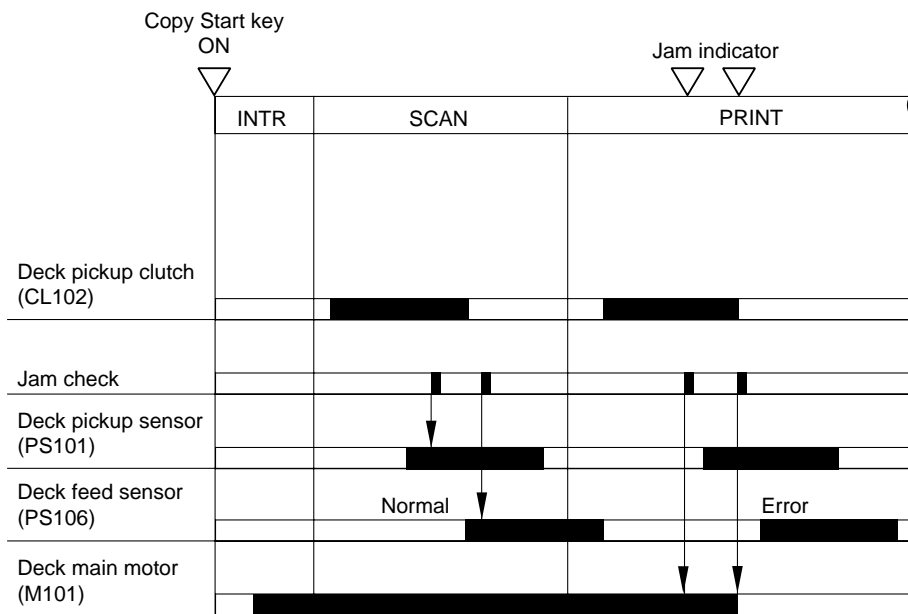

F-2-14

---

## Chapter 3 Parts Replacement Procedure

---





---

# Contents

3.1 Removing from the Host Machine.....	3-1
3.1.1 Compartment.....	3-1
3.1.1.1 Removing the Compartment.....	3-1
3.1.2 Paper Deck.....	3-1
3.1.2.1 Detaching the Deck from the Copier.....	3-1
3.1.2.2 Changing the Deck Paper Size.....	3-2
3.1.2.3 Adjusting the Deck Registration.....	3-2
3.1.2.4 Adjusting the Position of the Roll.....	3-3
3.2 External Covers.....	3-3
3.2.1 External Covers.....	3-3
3.2.1.1 External Covers.....	3-3
3.2.2 Front Cover.....	3-3
3.2.2.1 Removing the Front Cover.....	3-3
3.2.3 Rear Cover.....	3-4
3.2.3.1 Removing the Rear Cover.....	3-4
3.2.4 Right Cover.....	3-4
3.2.4.1 Removing the Right Cover.....	3-4
3.2.5 Upper Cover.....	3-5
3.2.5.1 Removing the Upper Cover.....	3-5
3.3 Drive System.....	3-5
3.3.1 Deck Pickup Clutch.....	3-5
3.3.1.1 Removing the Deck Pickup Clutch (CL102).....	3-5
3.3.2 Deck Feed Clutch.....	3-5
3.3.2.1 Removing the Deck Feeding Clutch (CL101).....	3-5
3.3.3 Deck Main Motor.....	3-6
3.3.3.1 Removing the Deck Main Motor (M101).....	3-6
3.3.4 Deck Lifter Motor.....	3-6
3.3.4.1 Removing the Deck Lifter Motor (M102).....	3-6
3.3.5 Lifter Cable (Front).....	3-6
3.3.5.1 Removing the Lifter Cable (front of the deck).....	3-6
3.3.6 Lifter Cable.....	3-7
3.3.6.1 Removing the Lifter Cable (rear of the deck).....	3-7
3.3.6.2 Routing the Lifter Cable.....	3-8
3.4 Document Feeding System.....	3-8
3.4.1 Deck Pickup Unit.....	3-8
3.4.1.1 Removing the Deck Pickup Unit.....	3-8
3.4.2 Deck Pickup Roller.....	3-9
3.4.2.1 Removing the Deck Pickup Roller.....	3-9
3.4.2.2 Orientation of the Deck Pickup Roller.....	3-9
3.4.3 Deck Pickup/Feed Roller.....	3-9
3.4.3.1 Removing the Deck Pickup/Feeding Roller.....	3-9
3.4.3.2 Orientation of the Deck Pickup/Feeding Roller.....	3-9
3.4.4 Deck Separation Roller.....	3-10
3.4.4.1 Removing the Deck Separation Roller.....	3-10
3.4.4.2 Adjusting the Pressure of the Deck Separation Roller.....	3-10
3.4.5 Deck Pick-up Sensor.....	3-10
3.4.5.1 Removing the Deck Pickup Sensor Unit.....	3-10
3.4.6 Deck Feed Sensor.....	3-10
3.4.6.1 Removing the Deck Feed Sensor Unit.....	3-10
3.5 Electrical System.....	3-11
3.5.1 Deck Driver PCB.....	3-11
3.5.1.1 Removing the Side Deck Driver PCB.....	3-11

3.5.2 Open Switch PCB .....	3-11
3.5.2.1 Removing the Open Switch PCB.....	3-11

## 3.1 Removing from the Host Machine

### 3.1.1 Compartment

#### 3.1.1.1 Removing the Compartment

- 1) Place a stack of copy paper [3] (about 8 cm in height) on the floor for placement of the deck [2] to prevent deformation of the roll support plate [1].

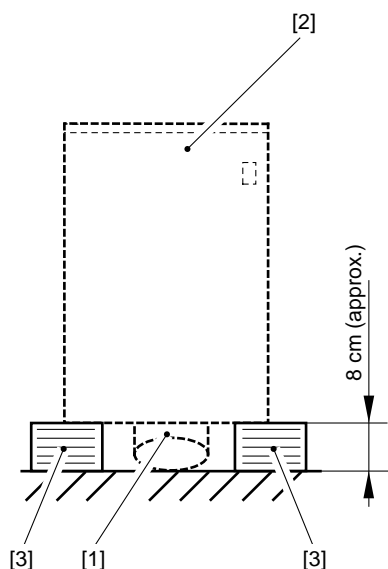

F-3-1

- 2) Detach the deck from the copier, and push down the latch plate [5] of the compartment [4] to open the compartment [4].

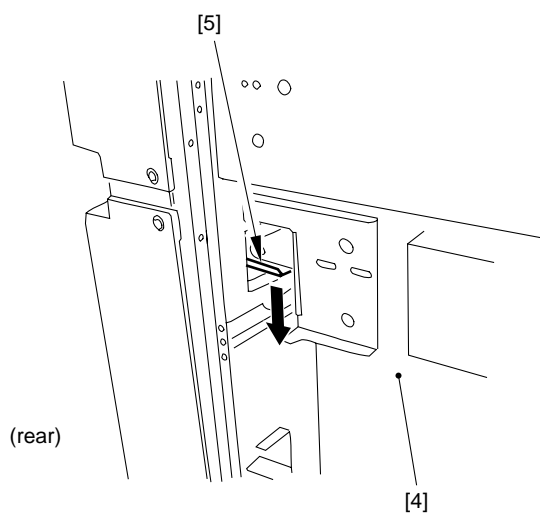

F-3-2

- 3) Remove the screw [6] and the stopper plate [7]; then, slide the compartment [8] farther out.

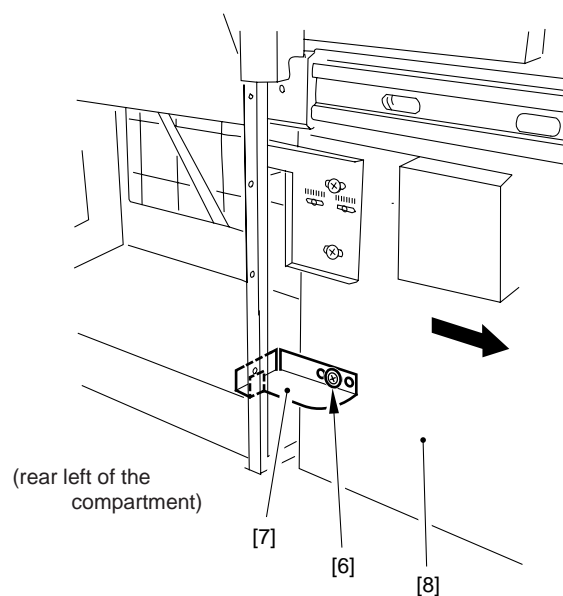

F-3-3

- 4) Remove the right cover.
- 5) Remove the screw [9] of the harness guide, and disconnect the connector [10]; then, remove the three left and right screws (each) [12], and detach the compartment [8] toward the front while lifting it slightly.
- 6) Place the compartment [8] on the stack of copy paper prepared in step 1).

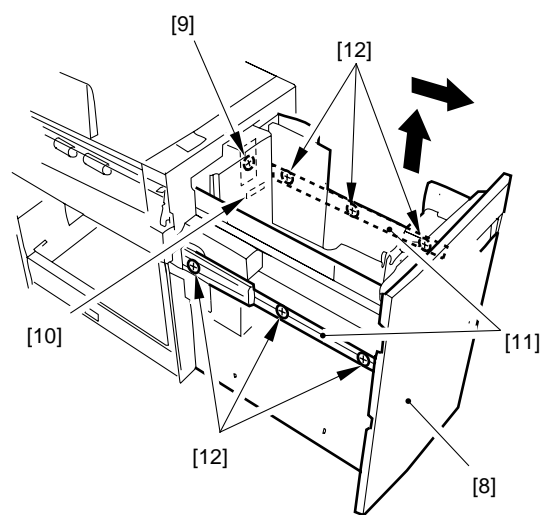

F-3-4

### 3.1.2 Paper Deck

#### 3.1.2.1 Detaching the Deck from the Copier

- 1) Place a stack of copy paper [3] (about 8 cm in height) on the floor for placement of the deck [2] to prevent deformation of the roll support plate [1].

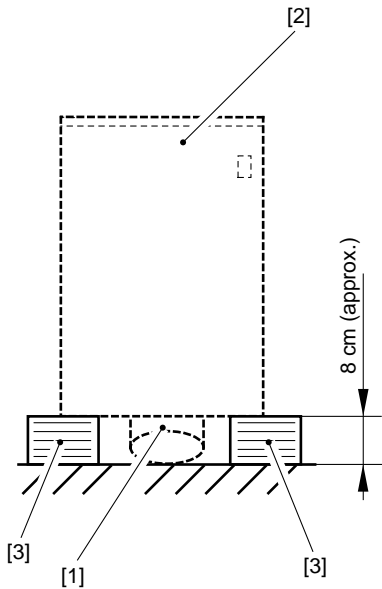

F-3-5

- 2) Remove the right cover.
- 3) Remove the four screws [5], and detach the deck [6] from the deck base [7].

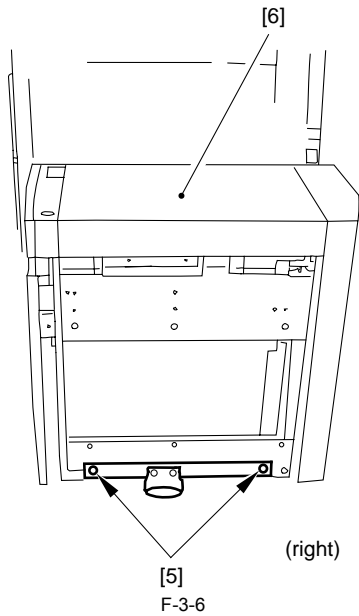

F-3-6

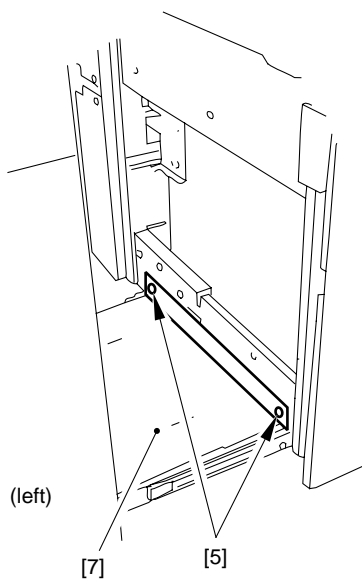

F-3-7

- 4) Hold the deck [8] as shown, and place it on the stack of paper prepared in step 1).

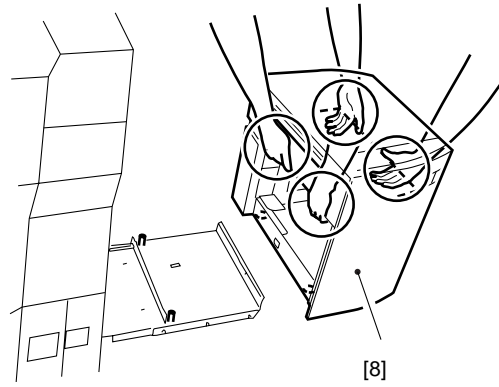

F-3-8

### 3.1.2.2 Changing the Deck Paper Size

If the user wishes to change the paper size of the deck, perform the following:

- 1) Open the compartment of the deck, and remove all paper.
- 2) If the lifter of the deck is up, turn on the copier's power switch, and push down the sensor lever [2] of the paper supply position sensor inside the compartment [1] to move down the lifter to its lower limit.

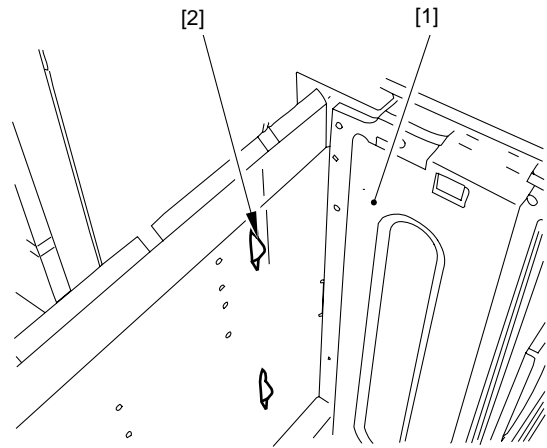

F-3-9

- 3) Remove the screw [3], and mount the paper trailing edge guide plate [4] to suit the new paper size.
- 4) Likewise, remove one screw each [5], and mount the left and right guide plates [6] to suit the new paper size.
- 5) Enter the new paper size in the copier's service mode (OPTION > ACC > DK-P).

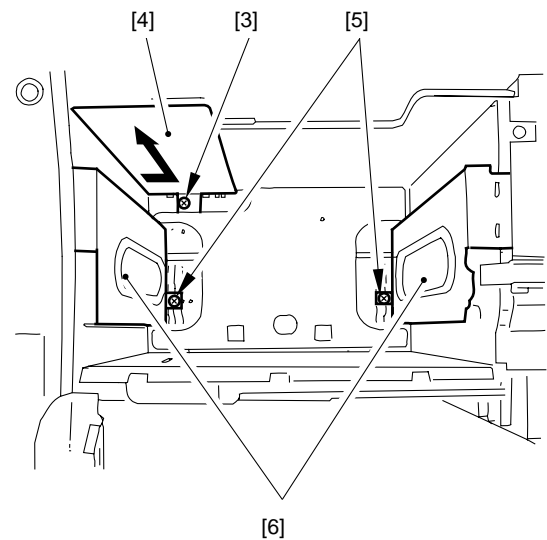

F-3-10

### 3.1.2.3 Adjusting the Deck Registration

If the left/right registration (standard of 0 +/-1.5 mm) needs to be adjusted,

perform the following:

- 1) Slide out the compartment, and adjust the position of the latch plate [1] of the deck open solenoid (SL102) using the two screws [2]. (At this time, use the scale graduation [3] on the latch plate as a guide.)

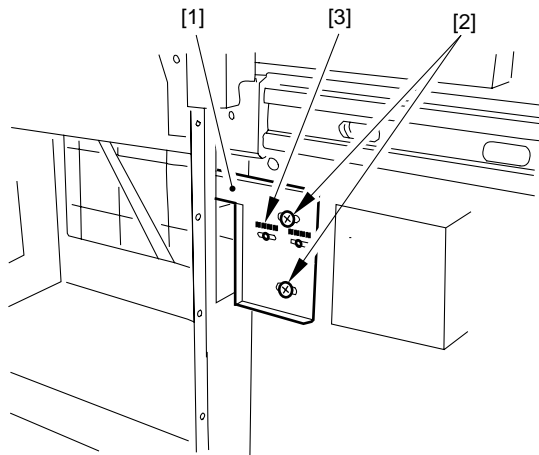

(rear left of the compartment)

F-3-11

### 3.1.2.4 Adjusting the Position of the Roll

If the compartment cannot be opened/closed smoothly, requiring adjustment of the position for the roll mounted to the front of the deck, perform the following:

- 1) Remove the front cover.
- 2) With the compartment fully slid out, turn the four mounting screws [4] on the roll support plate [3] so that the roll [1] is about 3 mm from the floor [2]. (Use the scale graduation [5] on the front side plate as a guide.)

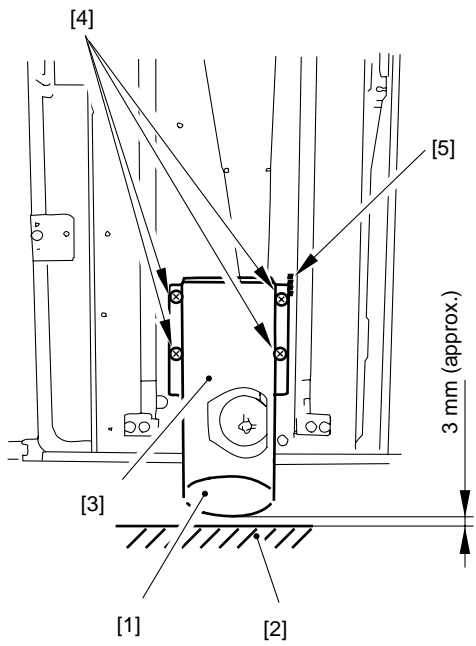

F-3-12

## 3.2 External Covers

### 3.2.1 External Covers

#### 3.2.1.1 External Covers

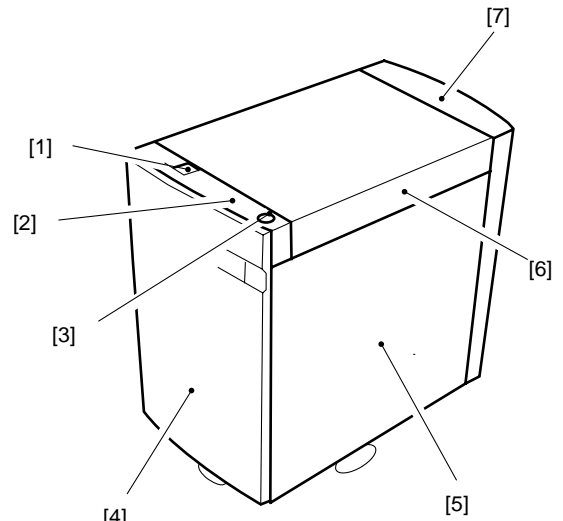

F-3-13

- [1] Deck releasing grip
- [2] Upper front cover
- [3] Compartment open/closed detecting switch
- [4] Front cover
- [5] Right cover
- [6] Upper cover
- [7] Rear cover

### 3.2.2 Front Cover

#### 3.2.2.1 Removing the Front Cover

- 1) Release the deck from the copier, and push down the latch plate [2] of the compartment [1]; then, open the compartment [1].

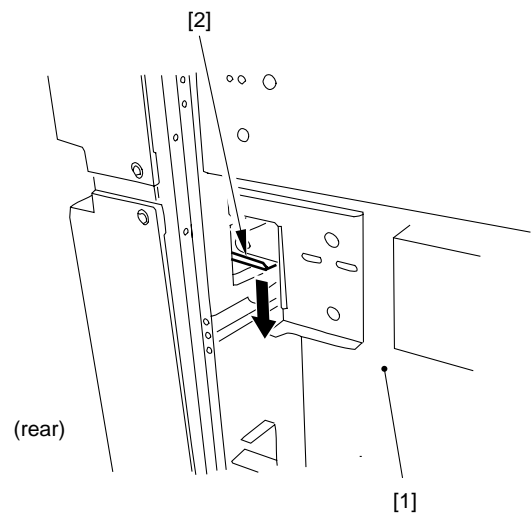

F-3-14

- 2) Loosen the four screws [3], and remove the front cover [4] of the deck toward the front.

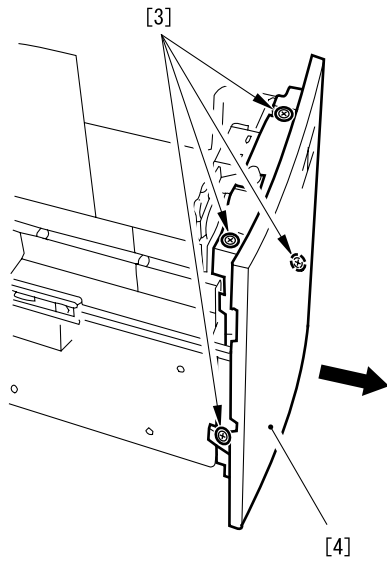

F-3-15



When mounting the front cover to the deck, be sure to match the coupling used as a paper level indicator.

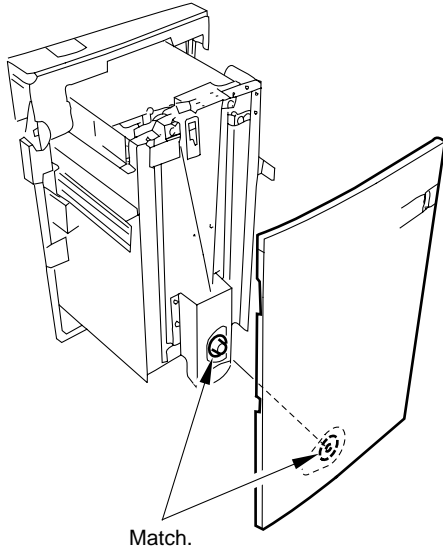

F-3-16



When mounting the front cover, be sure that the gap between the front cover and the upper front cover is 3 +/-1 mm.

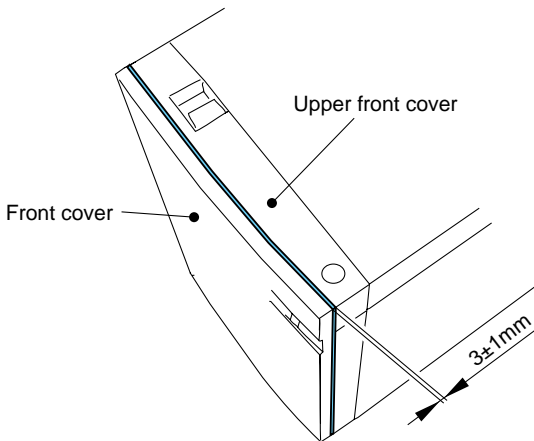

F-3-17



If you inadvertently moved the drive belt for the paper level indicator behind the front cover when removing the front cover and cannot find its initial position, or moved the deck lifter, move down the deck lifter to its lower limit, and move the drive belt in the direction of the arrow (thereby increasing the while area) until it stops; then, mount the front cover. (Operating the deck without matching the paper level indicator and the deck lifter position can damage the drive mechanism of the paper level indicator.)

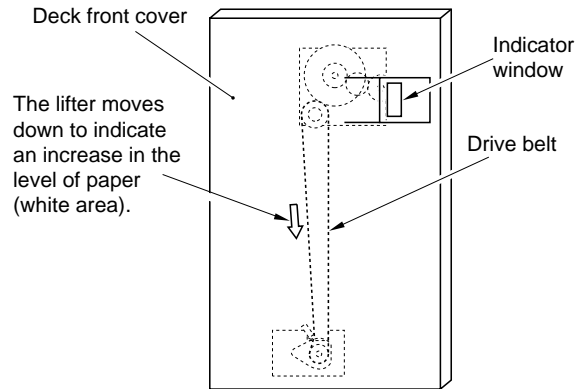

F-3-18

### 3.2.3 Rear Cover

#### 3.2.3.1 Removing the Rear Cover

- 1) Release the deck, and remove the six screws [1]; then, detach the rear cover [2].

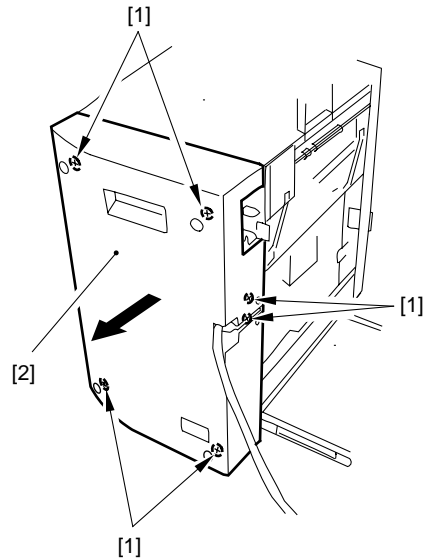

F-3-19

### 3.2.4 Right Cover

#### 3.2.4.1 Removing the Right Cover

- 1) Remove the three screws [1], and move the right cover [2] to the front; then, remove it toward the rear.

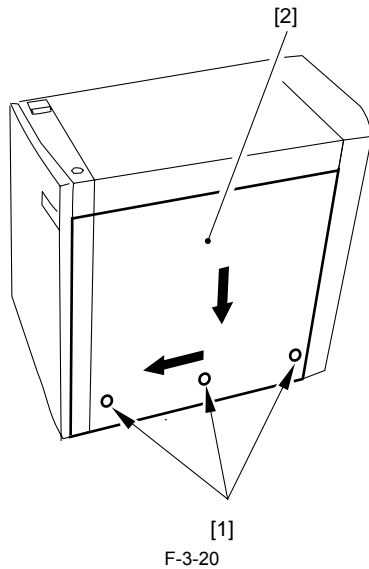

F-3-20

### 3.2.5 Upper Cover

#### 3.2.5.1 Removing the Upper Cover

- 1) Remove the rear cover.
- 2) Push down the latch plate [2] of the compartment [1] to open the compartment [1].

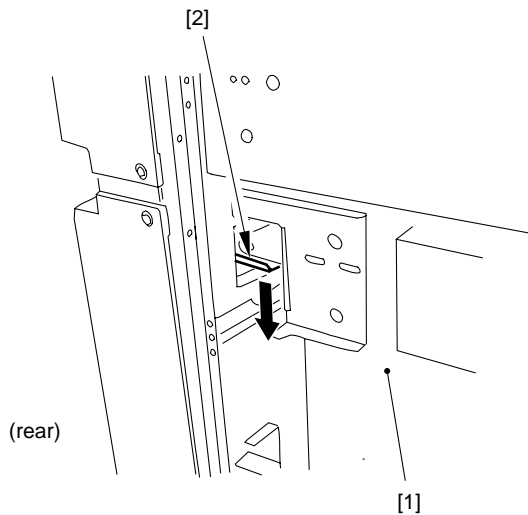

F-3-21

- 3) Remove the three screws [3], and disconnect the connector [4]; then, remove the upper front cover [5].

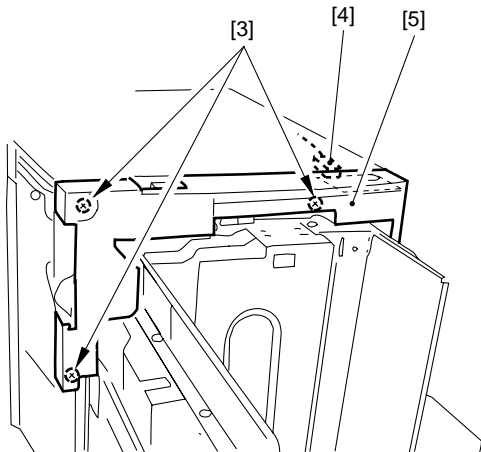

F-3-22

- 4) Remove the two screws [6]; then, detach the upper cover [7].

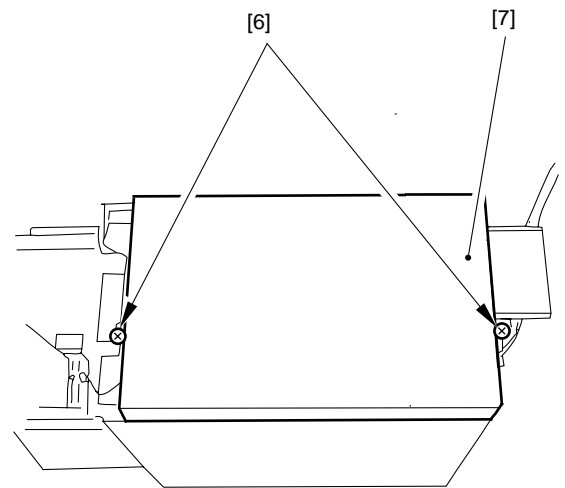

F-3-23

### 3.3 Drive System

#### 3.3.1 Deck Pickup Clutch

##### 3.3.1.1 Removing the Deck Pickup Clutch (CL102)

- 1) Remove the deck pickup unit.
- 2) Disconnect the connector [1] and the E-ring [2]; then, detach the deck pickup clutch [3].



When mounting the pickup clutch, be sure to put the clutch into the slip stop [4].  
Be sure also to hook the harness on the U-groove [5] of the guide.

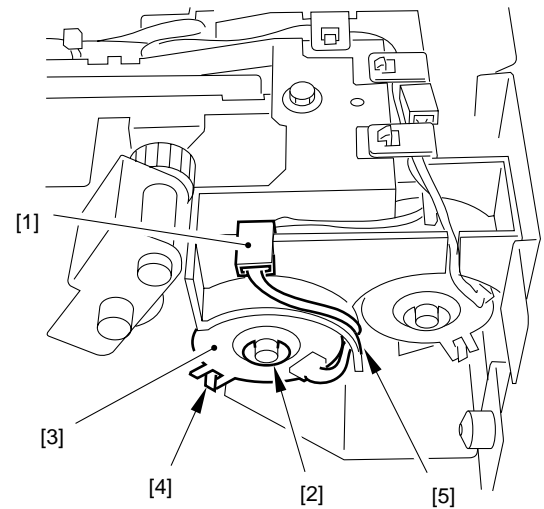

F-3-24

#### 3.3.2 Deck Feed Clutch

##### 3.3.2.1 Removing the Deck Feeding Clutch (CL101)

- 1) Remove the deck pickup unit.
- 2) Remove the harness retainer [1], and disconnect the connector [2]; then, remove the E-ring [3], and detach the deck feeding clutch [4].



When mounting the feeding clutch, be sure to put the clutch into the slip stop [5].

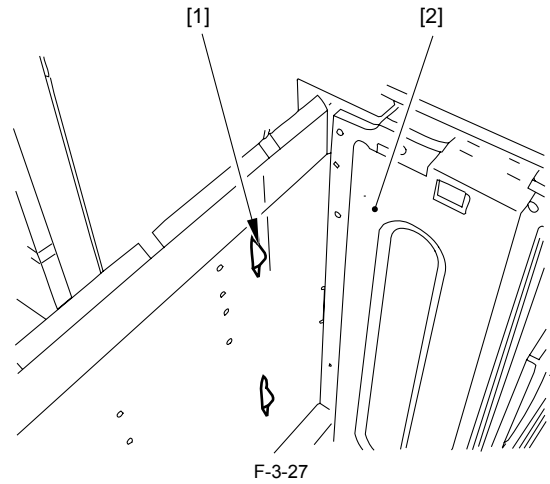
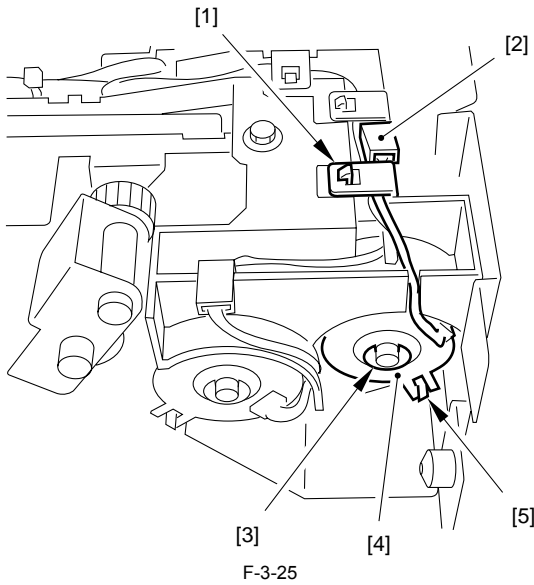

F-3-27

### 3.3.3 Deck Main Motor

#### 3.3.3.1 Removing the Deck Main Motor (M101)

- 1) Detach the deck from the copier, and remove the six screws; then, detach the rear cover.
- 2) Disconnect the two connectors [1], and remove the four screws [2]; then, detach the deck main motor [3].  
At this time, take care not to damage the gear at the tip of the motor spindle.

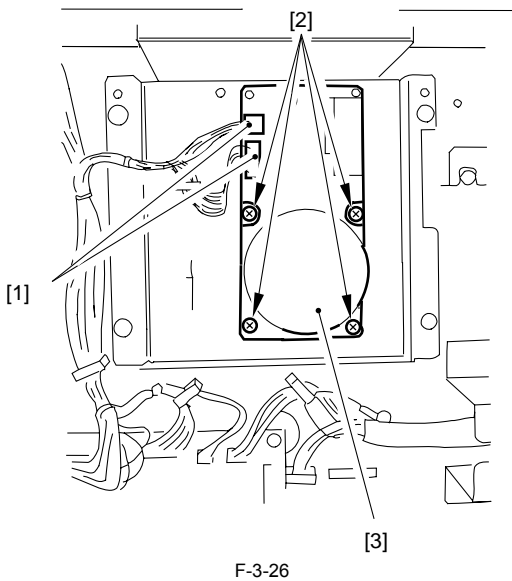

F-3-26

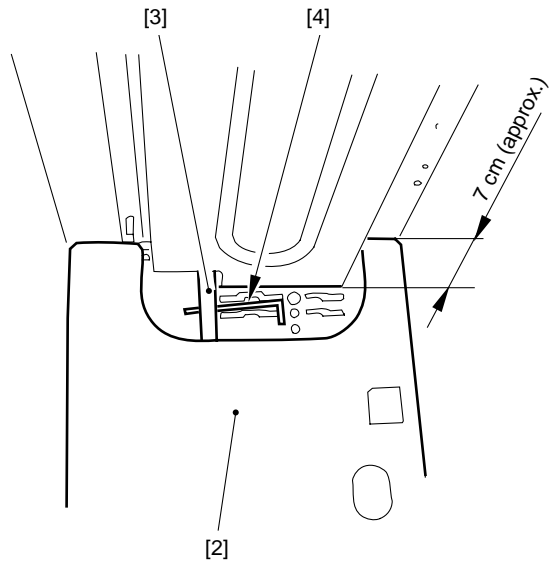

F-3-28

- 3) Take out the compartment from the deck.
- 4) Disconnect the connector [5], and remove the five screws [6]; then, detach the deck lifter motor unit [7].

### 3.3.4 Deck Lifter Motor

#### 3.3.4.1 Removing the Deck Lifter Motor (M102)

- 1) Open the compartment of the deck, and remove all copy paper.
- 2) Turn on the copier's power. If the lifter of the deck is up, push down the sensor lever [1] of the paper supply position sensor. Stop the lifter [2] when it is about 7cm from the base plate of the compartment, and insert a hex wrench into the hole of the lifter drive shaft [3] to hold it in place (thereby preventing it from rotating).

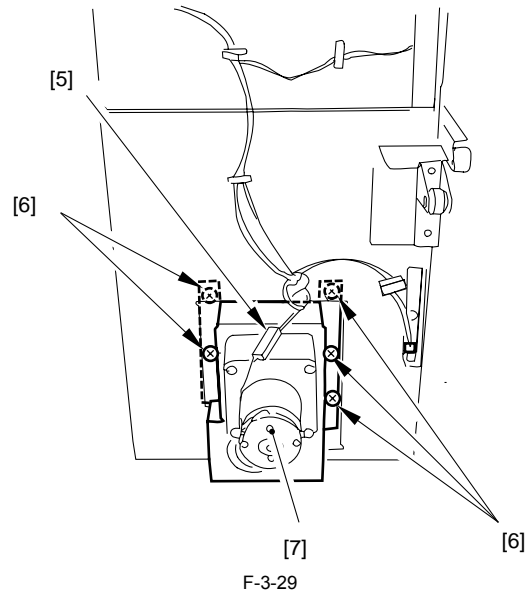

F-3-29

### 3.3.5 Lifter Cable (Front)

#### 3.3.5.1 Removing the Lifter Cable (front of the deck)

- 1) Open the compartment of the deck, and remove all paper.
- 2) Remove the screw, and detach the paper trailing edge guide plate from



inside the compartment.

- 3) Push the lever [1] of the paper supply position sensor inside the compartment to move down the lifter; when the holes on the left and right of the compartment side plate and the holes on the left and right of the lifter match, insert two long screwdrivers [2] through the holes to hold the lifter in position.

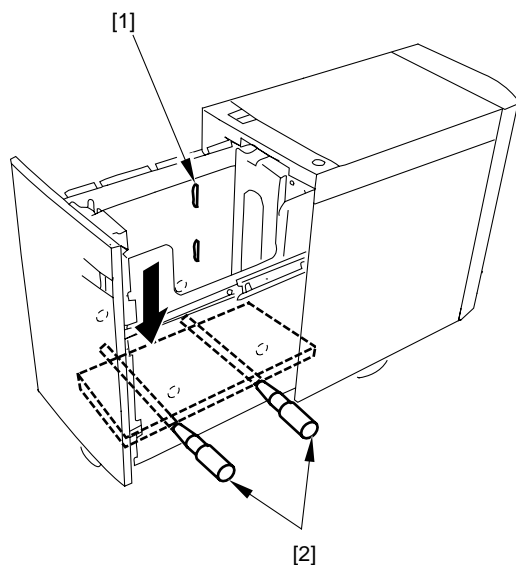

F-3-30

- 4) Remove the front cover of the deck.
- 5) Remove the four screws [3], and detach the roll support plate [4].

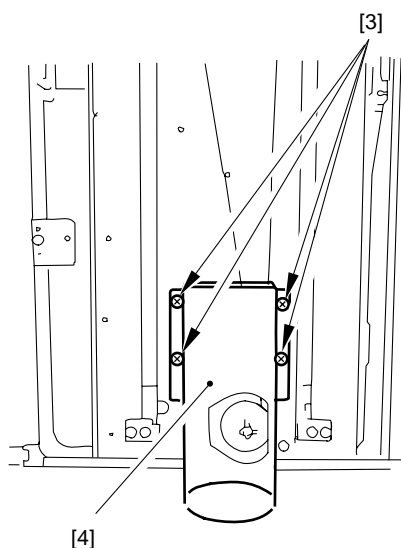

F-3-31

- 6) Remove the coupling shaft [5] and the E-ring [6]; then, detach the pulley cover [7].
- 7) Remove the two screws [8], and detach the cable fixing plate [9] on the left side; then, detach the lifter cable [10] on the outside.
- 8) Remove the two screws [11], and detach the cable fixing plate [12] on the right side; then, detach the lifter cable [13] on the inside.
- 9) To detach the lifter cable [13] on the inside from the pulley [14] on the inside, remove the two set screws [16] on the pulley [15] on the outside, and detach the pulley [15] on the outside.

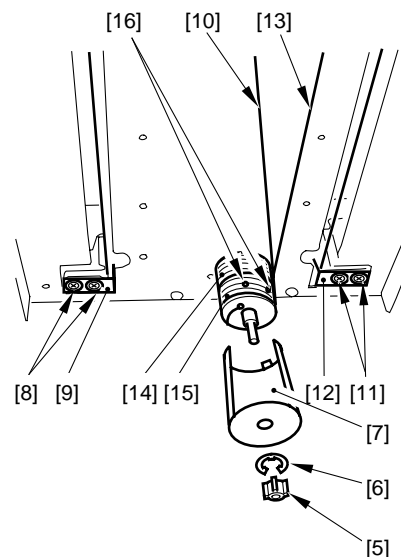

F-3-32

### 3.3.6 Lifter Cable

#### 3.3.6.1 Removing the Lifter Cable (rear of the deck)

- 1) Open the deck, and remove all paper.
- 2) Remove the screw, and detach the paper trailing edge guide plate from inside the compartment.
- 3) Push down the lever [1] of the paper supply position sensor inside the compartment to move down the lifter until the left and right holes in the compartment side plate and the left and right holes of the lifter match; then, insert two long screwdrivers [2] through the holes. At this time, match the top surface of the lifter with the marking on the compartment left side plate to facilitate matching the holes.

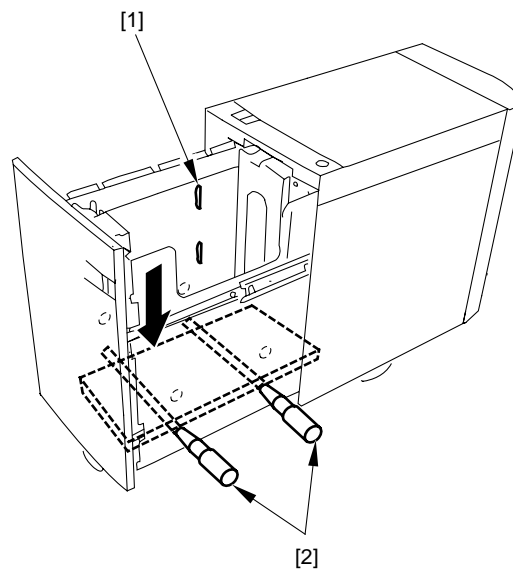

F-3-33

- 4) Remove the compartment.
- 5) Remove the screw [3], and detach the sensor plate [4].
- 6) Remove one screw each [5], and detach the sensor cover upper/lower [6].
- 7) Disconnect the two connectors [7], and remove the five screws [8]; then, detach the metal plate [9].

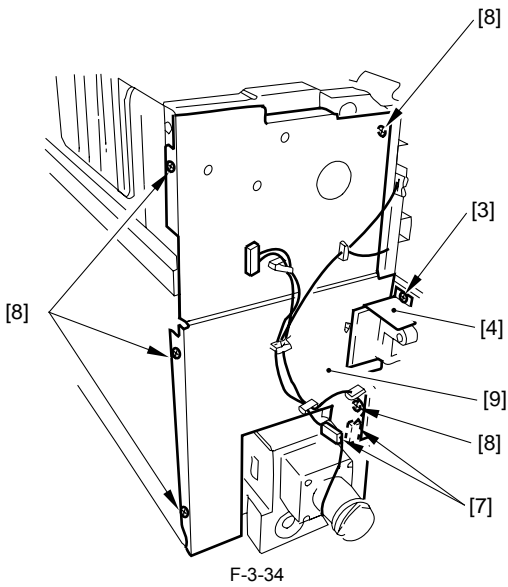

F-3-34

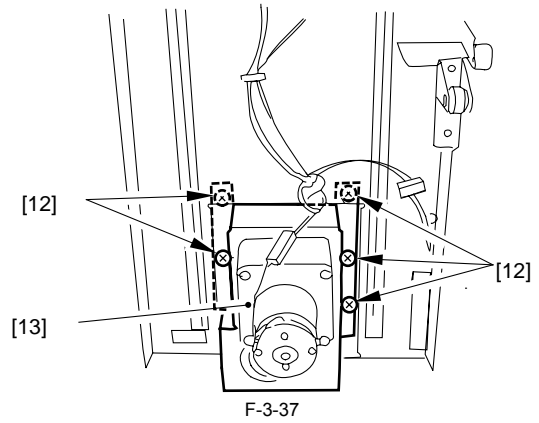

F-3-37

### 3.3.6.2 Routing the Lifter Cable

- 1) Check to make sure that the lifter drive shaft and the lifter are held in place with a hex wrench [1] and long screwdrivers [2].
- 2) Secure the cable fixing plate [3] to the lifter with two screws.
- 3) Hook the lifter cable on the upper pulley [4].
- 4) Hook the ball of the lifter cable on the pulley [5] of the lifter drive shaft; then, wind the cable along the groove of the pulley about 1.5 times. At this time, be sure to keep the lifter cable taut until the long screwdrivers are slightly lifted and stopped.
- 5) Secure the pulley to the lifter drive shaft with two set screws [6].
- 6) Mount all pulleys that have been removed back to the lifter drive shaft; then, measure the height from the base plate of the compartment to the top face of the lifter to ensure that the lifter is level.

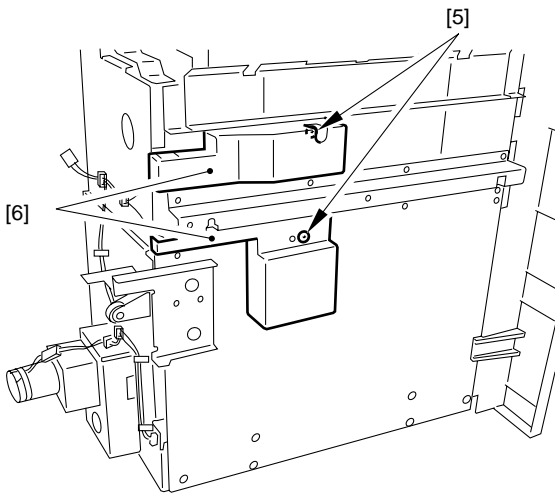

F-3-35

- 8) Insert a hex wrench [11] into the hole of the lifter drive shaft [10] to hold it in place (thereby preventing it from rotating).



If you fail to prevent the lifter drive shaft from rotating, the lifter cable will become slack as soon as you remove the lifter motor unit.

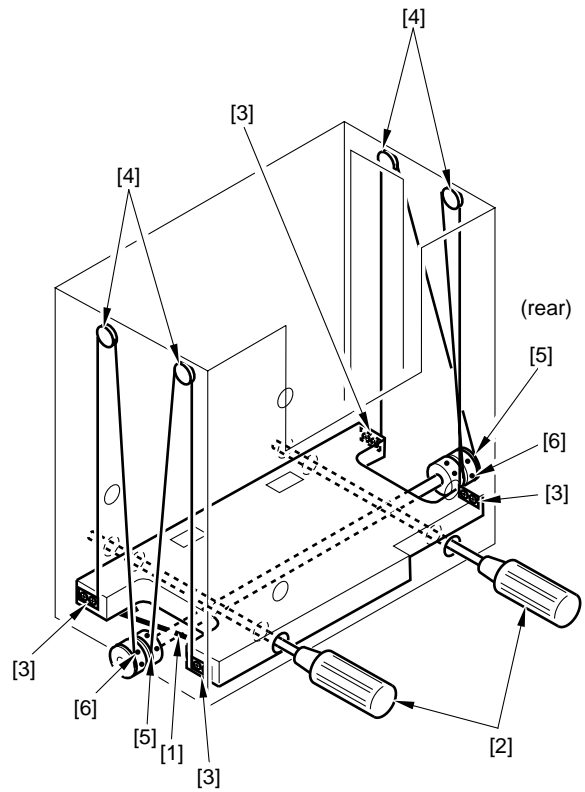

F-3-38

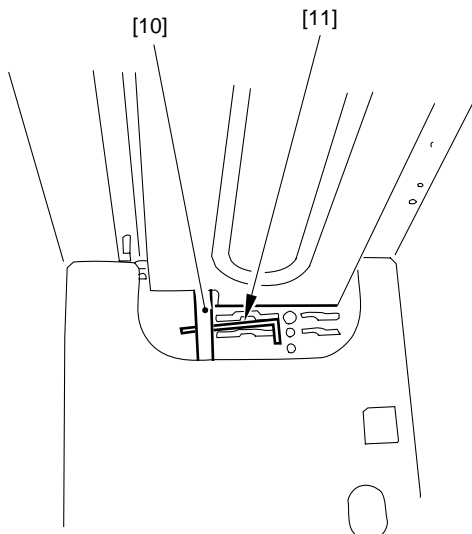

F-3-36

- 9) Remove five screws [12], and detach the lifter motor unit [13].

## 3.4 Document Feeding System

### 3.4.1 Deck Pickup Unit

#### 3.4.1.1 Removing the Deck Pickup Unit

- 1) Remove the upper cover.
- 2) Disconnect the two connectors [1], and remove the five screws [2].
- 3) Remove the deck pickup unit [3].

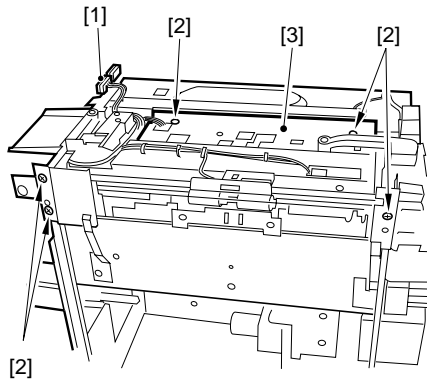

F-3-39



When mounting the deck pickup unit [3], be sure to use the three screws [4] shown in Figure.

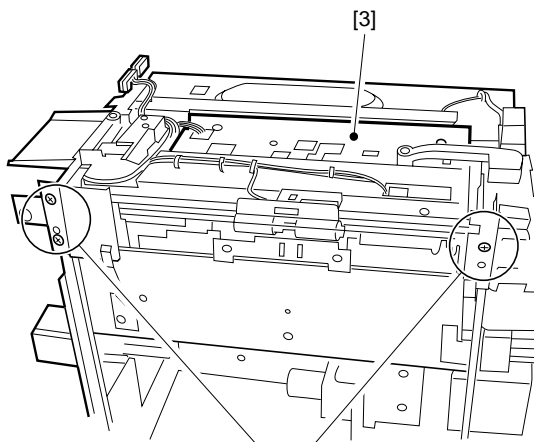

F-3-40

### 3.4.2 Deck Pickup Roller

#### 3.4.2.1 Removing the Deck Pickup Roller

- 1) Remove the deck pickup unit.
- 2) Turn over the deck pickup unit; then, remove the resin ring [1] (one each), and detach the deck pickup roller [2].

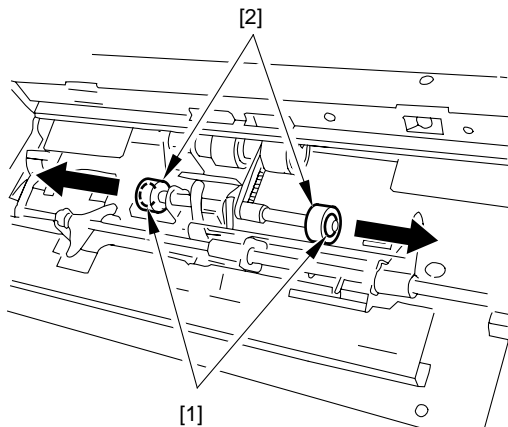

F-3-41

#### 3.4.2.2 Orientation of the Deck Pickup Roller

When mounting the deck pickup roller [1] at the front, be sure that the marking [2] on the collar (silver) is toward the front and the marking [3] on the side of the roller is toward the rear.

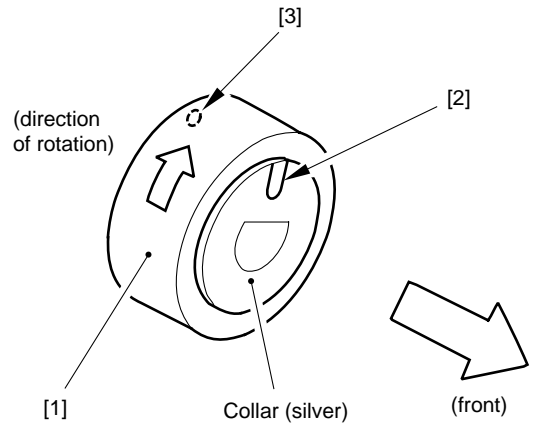

F-3-42

When mounting the deck pickup roller [4] at the rear, be sure that the marking [5] on the side of the roller and the marking [6] on the collar (silver) are toward the rear.

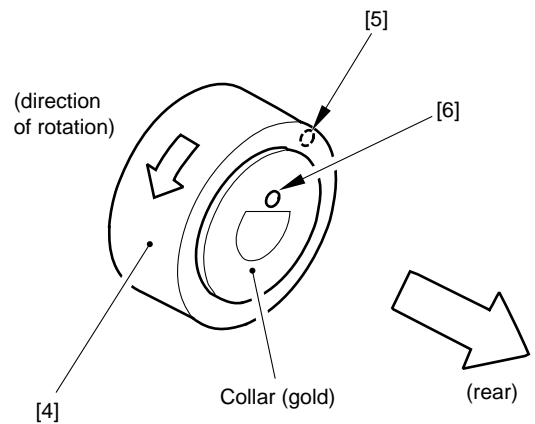

F-3-43

### 3.4.3 Deck Pickup/Feed Roller

#### 3.4.3.1 Removing the Deck Pickup/Feeding Roller

- 1) Remove the deck pickup unit.
- 2) Turn over the deck pickup unit.
- 3) Remove the resin ring [1], and detach the deck pickup/feeding roller [2] and the drive belt [3] toward the front.

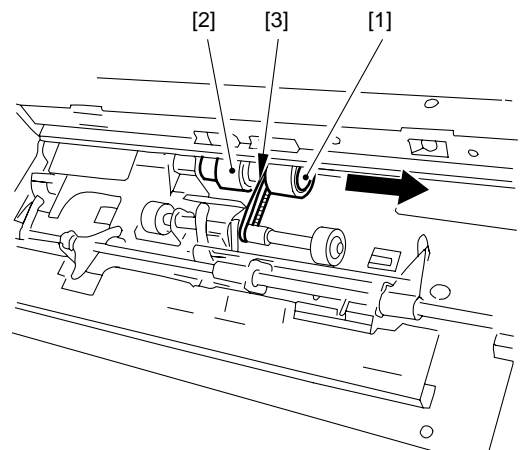

F-3-44

#### 3.4.3.2 Orientation of the Deck Pickup/Feeding Roller

When mounting the deck pickup/feeding roller [1], be sure that the belt pulley [2] is toward the front.

When mounting the pickup/feeding roller rubber piece to the pickup/feeding roller shaft, be sure that the marking [3] is toward the rear.

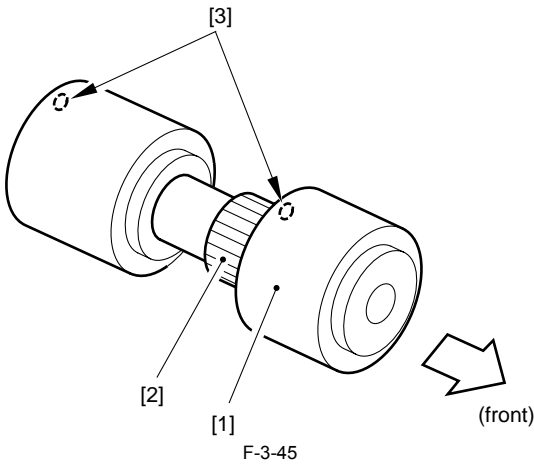

F-3-45

### 3.4.4 Deck Separation Roller

#### 3.4.4.1 Removing the Deck Separation Roller

- 1) Detach the deck from the copier, and remove the two screws [1]; then, detach the separation roller support plate [2].

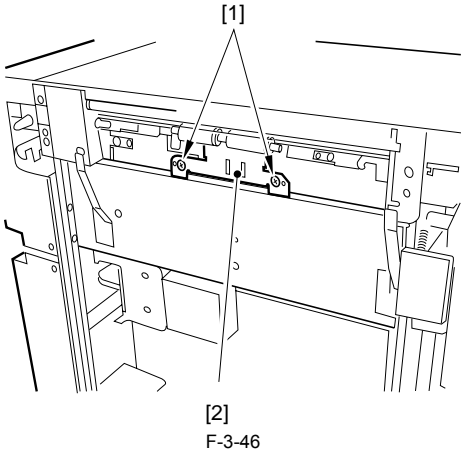

F-3-46

- 2) Remove the joint, and detach the deck separation roller [3].

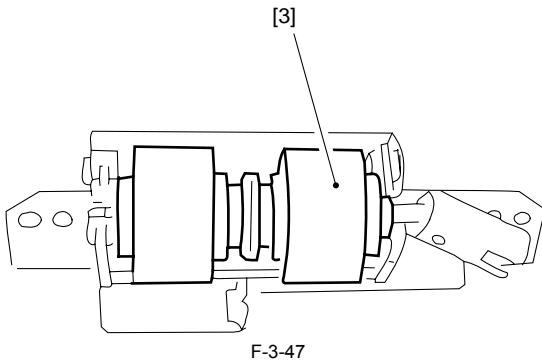

F-3-47



The urethane sponge used on the deck separation roller changes over time from initial pink to orange and then to yellow, accelerated if exposed to light. This is a general characteristic of urethane sponge, and does not affect its performance, and the part is not identified by color.

#### 3.4.4.2 Adjusting the Pressure of the Deck Separation Roller

- If double feeding or pickup failure occurs when the deck is used as the source of paper, change the position of the deck separation roller pressure spring:
- If pickup failure occurs, move the spring in the direction of arrow A.
  - If double feeding occurs, move the spring in the direction of arrow B.

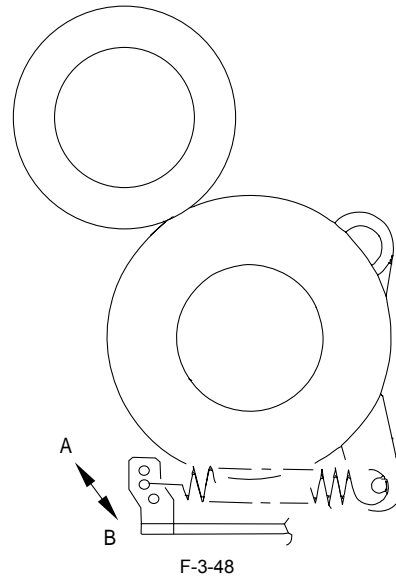

F-3-48

### 3.4.5 Deck Pickup Sensor

#### 3.4.5.1 Removing the Deck Pickup Sensor Unit

- 1) Remove the deck upper cover.
- 2) Remove the screw [1], and detach the deck pickup sensor unit [2].

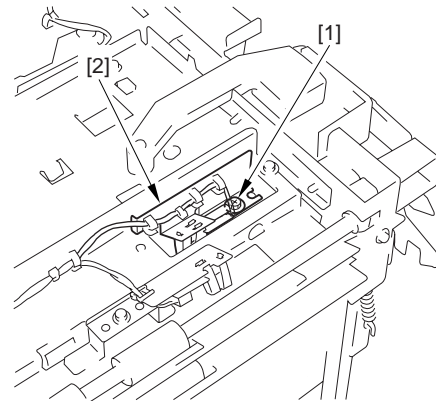

F-3-49

- 3) Disconnect the connector [1], and free the claw to detach the deck pickup sensor [2].



When removing the scanner sensor, be sure to remove the paint used to lock the claw in place in advance to prevent breaking the claw. When mounting it, be sure the claw is not displaced or the sensor is not disoriented.

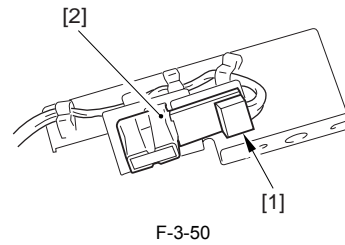

F-3-50

### 3.4.6 Deck Feed Sensor

#### 3.4.6.1 Removing the Deck Feed Sensor Unit

- 1) Remove the deck upper cover.
- 2) Remove the screw [1], and detach the deck feed sensor unit [2].

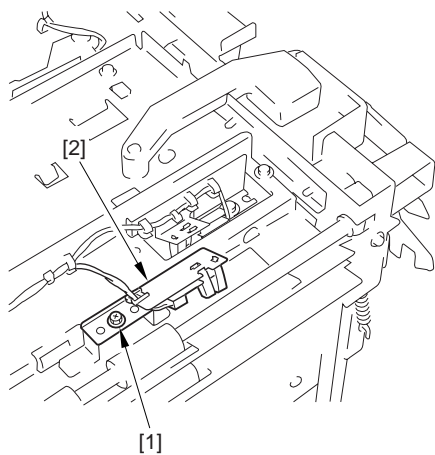

F-3-51

- 3) Disconnect the connector [1], and free the claw to remove the deck feed sensor [2].



When removing the scanner sensor, be sure to remove the paint used to lock the claw in place in advance to prevent breaking the claw. When mounting it, be sure the claw is not displaced or the sensor is not disoriented.

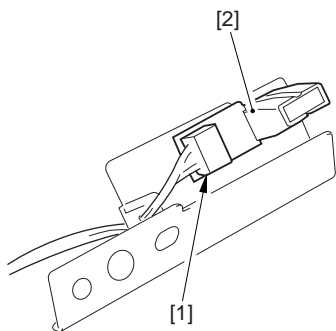

F-3-52

## 3.5 Electrical System

### 3.5.1 Deck Driver PCB

#### 3.5.1.1 Removing the Side Deck Driver PCB

- 1) Detach the deck from the copier; then, remove the six screws, and detach the rear cover.
- 2) Disconnect the nine connectors [1], and remove the four screws [2]; then, detach the deck driver PCB [3].

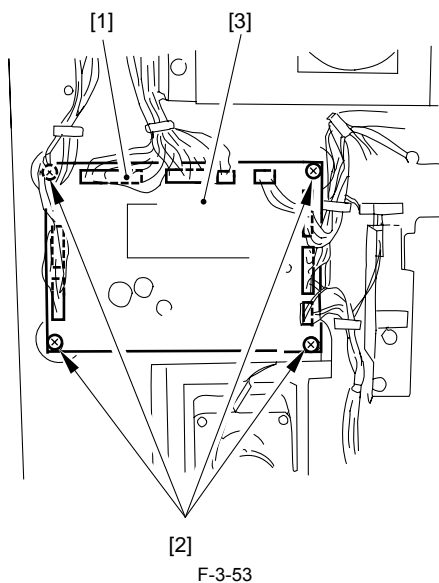

F-3-53

### 3.5.2 Open Switch PCB

#### 3.5.2.1 Removing the Open Switch PCB

- 1) Detach the deck from the copier, and push down the latch plate [2] of the compartment [1]; then, open the compartment [1].

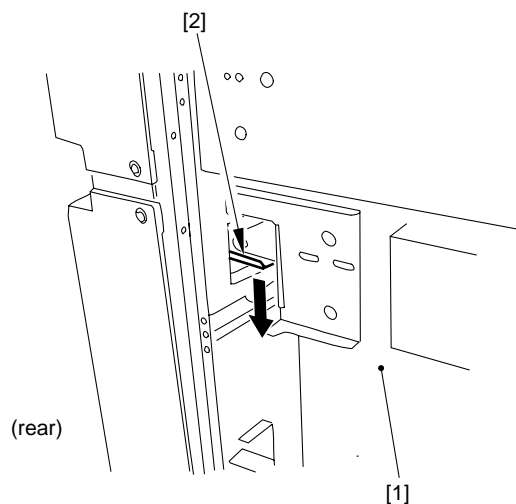

F-3-54

- 2) Remove the three screws [3], and disconnect the connector [4]; then, detach the upper front cover [5].

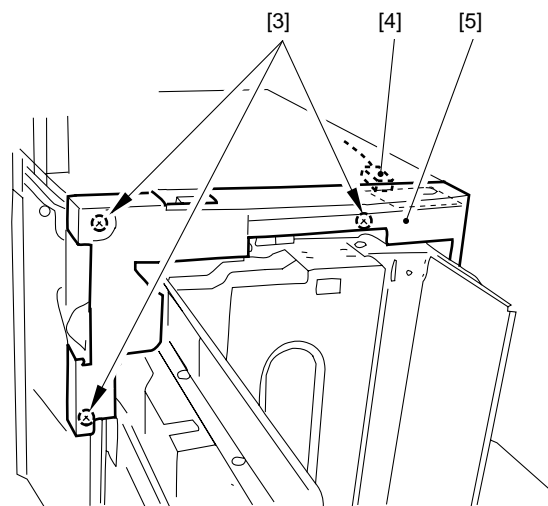

F-3-55

- 3) Remove the two screws [6], and detach the open switch PCB [7].

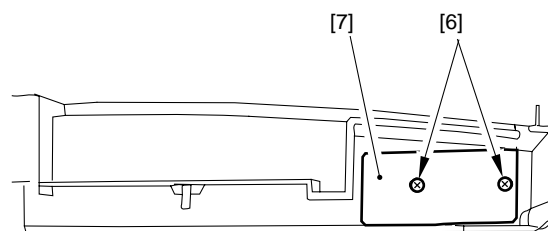

F-3-56



When mounting the upper front cover, take care to avoid trapping the harness by the open switch PCB and be sure to connect all connectors.



---

## Chapter 4 Maintenance

---





---

# Contents

4.1 Maintenance and Inspection.....	4-1
4.1.1 Periodically Replaced Parts .....	4-1
4.1.1.1 Periodically Replaced Parts.....	4-1
4.1.2 Durables .....	4-1
4.1.2.1 Guide to Replacement of Durables .....	4-1
4.2 Adjustment .....	4-2
4.2.1 Basic Adjustment .....	4-2
4.2.1.1 Adjusting the Image Front Margin.....	4-2
4.2.1.2 Orientation of the Pickup Roller .....	4-2
4.2.1.3 Orientation of the Feeding Roller .....	4-2
4.2.1.4 Positioning the Deck Pickup Roller Releasing Solenoid (SL101).....	4-2
4.3 Troubleshooting .....	4-3
4.3.1 Malfunction.....	4-3
4.3.1.1 Malfunction/Faulty Detection .....	4-3
4.3.1.1.1 Pickup fails.....	4-3
4.3.1.1.2 The deck lifter fails to move up (side paper deck).....	4-3
4.3.1.1.3 E043 .....	4-3
4.4 Outline of Electrical Components .....	4-4
4.4.1 Arrangement of Electric Parts.....	4-4



## 4.1 Maintenance and Inspection

### 4.1.1 Periodically Replaced Parts

#### 4.1.1.1 Periodically Replaced Parts

The machine does not have parts that require periodical replacement.



A periodically replaced part is one that must be replaced on a periodical basis to ensure a specific level of machine performance; once it fails, it can affect machine functions considerably regardless of its external appearance. If possible, schedule the replacement to coincide with scheduled servicing.

### 4.1.2 Durables

#### 4.1.2.1 Guide to Replacement of Durables

Some parts of the machine may prove to require replacement once or more over the period of product warranty because of wear or damage. Replace them when they fail; see the following for a guide:

T-4-1

No.	Parts name	Parts No.	Q'ty	Life (pages)	Remarks
1	Side Paper Deck Feed Roller	FF5-7829(front) FF5-7830(rear)	2	500,000	Actual number may be checked in service mode.* PD-PU-RL
2	Side Paper Deck Delivery Roller	FB6-0615	2	500,000	Actual number may be checked in service mode.* PD-FD-RL
3	Side Paper Deck Separation Roller	FB5-6586	1	500,000	Actual number may be checked in service mode.* PD-SP-RL

\* COPIER > COUNTER > DRBL-2.

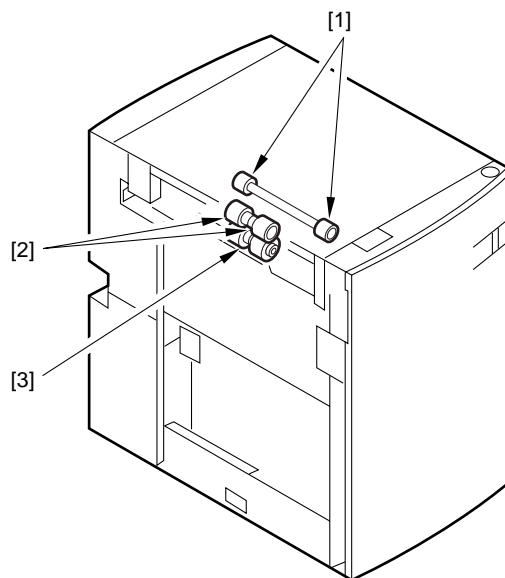

F-4-1

## 4.2 Adjustment

### 4.2.1 Basic Adjustment

#### 4.2.1.1 Adjusting the Image Front Margin

- 1) Place the NA3 Test Chart on the copyboard glass, and make a double-sided copy to check the front non-image width of the 2nd side image.  
Standard: 2.5 +/-1.5 mm

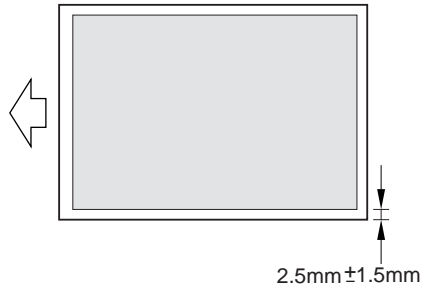

F-4-2

- 2) Slide out the compartment, and adjust the position of the latch plate [1] of the deck open solenoid using the 2 screws [2]. (At this time, use the index [3] on the latch plate as a reference.)

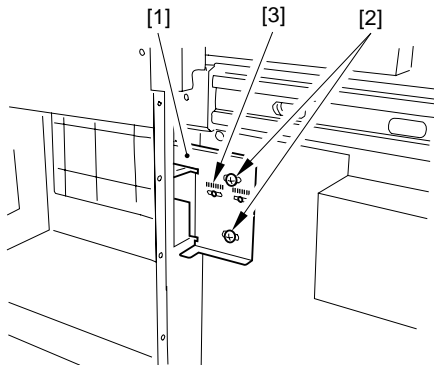

F-4-3

#### 4.2.1.2 Orientation of the Pickup Roller

The pickup roller may be mounted by reversing the steps used to remove it; however, keep the following in mind:

- The pickup rollers used at the front and the rear of the machine are not interchangeable.
- The collar of the pickup roller used at the front of the machine is silver-colored.

When mounting the pickup roller [1] to the pickup assembly, be sure that the round marking [2] of the color (silver-colored) is toward the front of the machine.

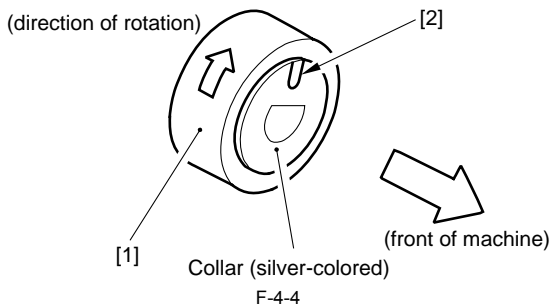

F-4-4

- [1] Pickup roller
- [2] Marking (collar)

- The collar of the pickup roller used at the rear of the machine is gold-colored.

When mounting the pickup roller [4] to the pickup assembly, be sure that the round marking [5] on the side of the roller and the round marking [6] on the collar (gold-colored) are toward the rear of the machine.

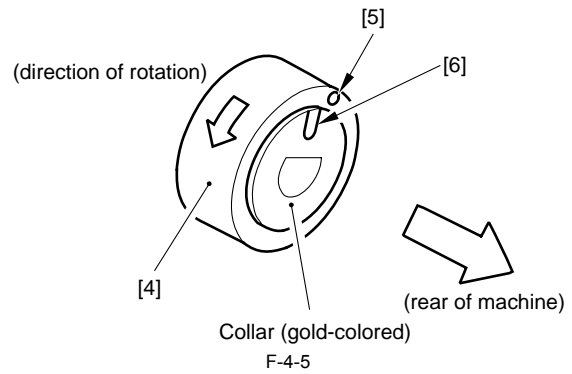

F-4-5

#### 4.2.1.3 Orientation of the Feeding Roller

When mounting the feeding roller assembly [1] to the side paper deck pickup assembly, be sure that the belt pulley [2] is toward the front of the machine. When mounting the feeding roller [3] to the feeding roller shaft [4], be sure that the round marking [5] is toward the rear of the machine.

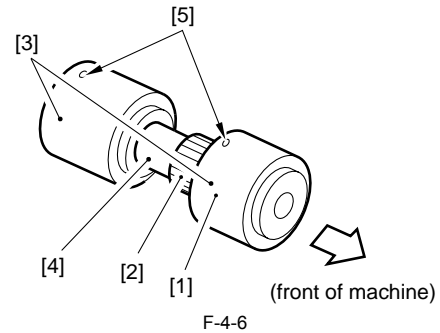

F-4-6

#### 4.2.1.4 Positioning the Deck Pickup Roller Releasing Solenoid (SL101)

Take note of the position of the two fixing screws [2] used for the deck pickup roller releasing solenoid [1] before detaching it from its support plate with reference to the scale graduations on the plate. Or, mark the position on the support plate with a scribe if you are replacing the solenoid on its own (in this case, be sure to mount it back to its initial position).

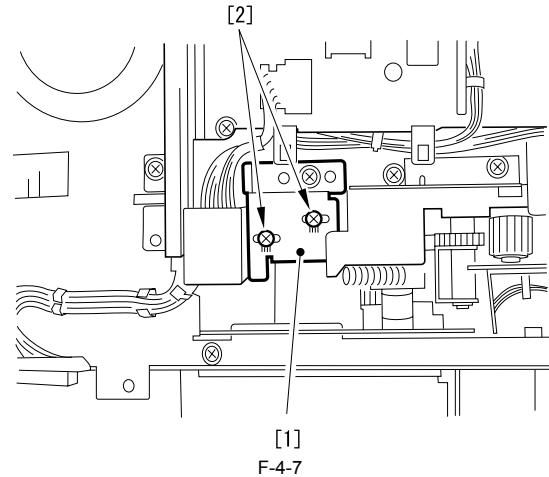

F-4-7

## 4.3 Troubleshooting

### 4.3.1 Malfunction

#### 4.3.1.1 Malfunction/Faulty Detection

##### 4.3.1.1.1 Pickup fails

0011-3089

Right upper door, Right lower door

- 1) Are the right upper door and the right lower door closed firmly?  
NO: Close the doors firmly.

Lifter

- 2) Does the lifter move down when the compartment is slid out from the deck? Also, is the sound of the lifter move up heard when the compartment is slid in?  
NO: See "The deck lifter fails to move up".

Deck pickup roller

- 3) Does the pickup roller rotate?  
YES: If the roller is soiled, clean it with alcohol.  
If it is deformed because of wear, replace it.

Drive belt, Gear, Coupling

- 5) Is the drive from the deck main motor transmitted to the pickup assembly through the drive belt, gear, and coupling?  
NO: Check the drive belt, gear, and coupling.

Side deck driver PCB output, Deck pickup/vertical path clutch (pickup, CL102; feed, CL101)

- 6) Measure the voltage of the following connectors on the side deck PCB. Does it change from 24 to 0 V when the Start key is pressed?
  - J104-7 (CL101)
  - J104-12 (CL102)
 NO: Replace the side deck driver PCB.  
YES: Check the wiring up to the clutch; if normal, replace the clutch.

##### 4.3.1.1.2 The deck lifter fails to move up (side paper deck)

0011-3092

Side paper deck

- 1) Is the deck mounted correctly?  
NO: Mount the deck correctly.

Lifter cable

- 2) Is the lifter cable strung correctly?  
NO: String the lifter cable correctly.

Spring, Lever

- 3) Push up the pickup roller releasing lever with your finger. Does the pickup roller move down?  
NO: Remove the pickup assembly, and check the spring and lever.

Deck lifter motor (M102)

- 4) Does the deck lifter motor rotate?  
YES: Go to step 6.

Deck lifter driver PCB, Deck open detecting switch (SW101)

- 5) Does the voltage between J109-3 on the side deck driver PCB and GND (-) change from about 0 to 5 V when the deck is closed?  
NO: Replace the side deck driver PCB.  
YES: Check the wiring up to the switch; if normal, replace the switch.

Deck lifer lower limit switch (SW102), Side deck driver PCB

- 6) Is the voltage between J107-8 (-) note side deck driver PCB and GND (-) as follows?
  - When the deck is opened, 0 V.
  - When the deck is closed, 5 V.
 YES: Check the lever and wiring; if normal, replace the sensor.  
NO: Replace the side deck driver PCB.

##### 4.3.1.1.3 E043

0011-3098

Side deck drive PCB

- 1) Is there electrical continuity between the following connectors on the side deck drive PCB?  
T-4-2

Signal	Connectors
38VU	J106-1 ↔ J101-1
0VU	J106-2 ↔ J101-2

NO: Replace the side deck driver PCB.

Deck main motor (M101), DC controller PCB

- 2) Try replacing the deck main motor (M101) of the side paper deck. Is the problem corrected?  
YES: End.  
NO: Check the harness from the DC controller PCB to the motor; if normal, replace the DC controller PCB.

## 4.4 Outline of Electrical Components

### 4.4.1 Arrangement of Electric Parts

T-4-3

Name	Notation
Deck pickup sensor	PS1
Deck paper absent sensor	PS2
Deck lifter upper limit sensor	PS3
Deck lift position sensor	PS4
Deck set sensor	PS5
Deck feed sensor	PS6
Deck paper supply position sensor	PS7
Deck paper level sensor	PS8
Compartment open sensor	PS9
Compartment open detecting switch	SW1
Deck lifter lower limit detecting switch	SW2
Compartment open switch	SW100
Deck main motor	M1
Deck lifter motor	M2
Deck feeding clutch	CL1
Deck pickup clutch	CL2
Deck pickup roller releasing solenoid	SL1
Compartment open solenoid	SL2
Deck heater (option for 200/230V model)	H1
Deck drive PCB	PCB1
Open switch PCB	PCB2

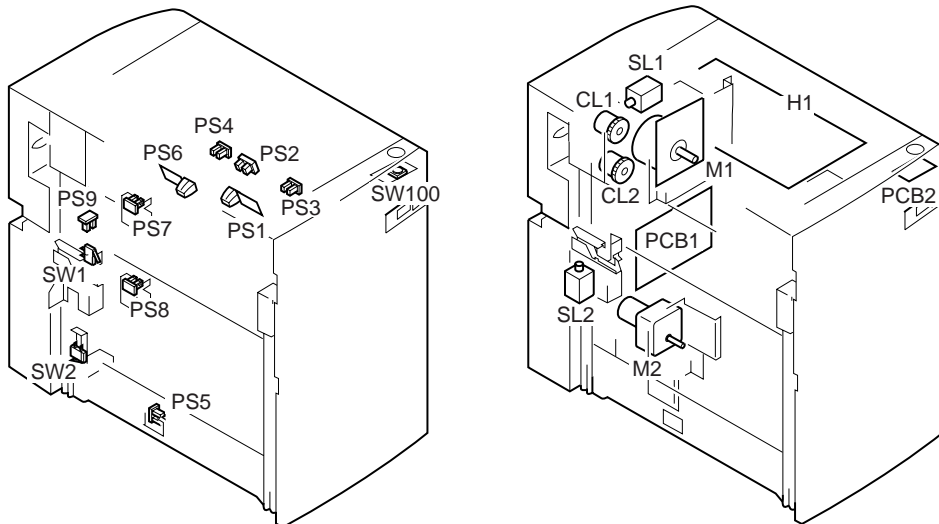

F-4-8

---

## Chapter 5 Error Code

---





# Contents

5.1 Overview .....	5-1
5.1.1 Outline.....	5-1
5.1.2 Error Code.....	5-1



---

## 5.1 Overview

---

### 5.1.1 Outline

The machine communicates its state to its host machine as needed for diagnosis by the host machine' CPU. The host machine will indicate a code on its control panel upon detection of an error, the nature of which may be checked in the host machine' service code. The following table shows the applicable codes and faults associated with them together with the timing of detection:

### 5.1.2 Error Code

E043

T-5-1

Code	Main cause	Condition
E043	The side paper deck main motor (M101) is faulty. The side deck driver PCB is faulty. The DC controller PCB is faulty.	0000 The PLL lock signal (DMPLK) does not arrive for 2 sec or more after the side paper deck main motor drive signal has been generated.



Feb 7 2006

**Canon**